

The L.B.& S.C.R. Modellers Digest

Issue 3
Summer 2016



A journal of the Brighton Circle, for those modelling the "Brighton" in all scales and gauges.

Crystal Palace Overhead Electric	3	Shorter Trains	68
Bricklayer's Arms Coke Shed 1844	9	Lewes visualisations Part 2	73
Cowans Sheldon Crane and Tender	20	Mystery Photo	79
Open A wagon	24	Low Cost Rolling Road	81
H2 Atlantic	27	E2 3D Printing	84
Vintner's Yard	29	Stroudley roof 3D printing	91
Belgravia	37	Cameo Plotter update	95
Signals for Newick and Chailey	41	Whitemetal casting	97
Travelling Hand Crane Part 2	52	New Books	103

Editorial

Yet again, the Digest has been well supported by authors who are keen to share modern techniques to build models of the pre-grouping period. Despite, or possibly because of the period modelled, various IT based approaches have been used to tackle the problems of modelling Victorian prototypes. In this edition, there is the follow up to the item in Issue 2, in which the patterns for a Craven carriage were generated on a Cameo Duplicutter. There are two very different approaches to 3D printing and there is more on the visualisation of Lewes station before its rebuilding. I find these new approaches both refreshing and exciting, as they add whole new dimensions to the hobby and offer new opportunities. This is in no way to denigrate the more traditional skills, which may involve decorating the streets of Vintner's Yard with horse poo, a dollop at a time. Like much in the Digest, those who model any of the pre grouping lines should find ideas that will read across.

On the basis that a six monthly publication seems to be about right, the next issue should appear around Christmas time again and it would be helpful to have any material by about mid November.

Eric Gates

Modelling Steward, The Brighton Circle

Crystal Palace Overhead Electric Set

By Eddie Carter

I decided some years ago to attempt to make model of a LBSCR Overhead Electric Set. There were three Overhead Electric versions that I could to choose from.

The South London sets.

The Crystal Palace Sets .

The Coulsdon/Wallington sets

When I decided to start construction the only drawings available were the ones in Peter Newbury's book. I am not sure if these have been improved upon, but I have seen them reproduced in other literature.

The South London coaches were made up into trains of two Motor Thirds and a First Trailer car. The First was soon removed from the sets and replaced with a Composite. The panelling on these coaches had square corners to the mouldings. The replacement cars had the normal rounded corners.

The CP sets were narrower than the SL ones, according to the drawing I made it about 1mm. (which I ignored)

These were made up into two car sets, with a Motor Third and a Composite coach. These were augmented with another Motor Brake Third as necessary and formed into multiples of these units.

The Coulsdon/Wallington sets were nominally five coach units, with two Third Driving Trailers, two Composites and a Motor Luggage Van in the middle. This was the prime mover.

I decided that the easiest option would be to construct a two car CP set, and if I was not too fed up at the end, to add on another Motor Third. I have not done that yet!

Looking around for easy-build options, I homed in on the Ratio panelled Midland coaches.



Trailer - side view

The biggest compromise that had to be made was on the use of a full Third body, as this made all the compartments the same width between the windows. This only affected the Trailer Composite. If you are looking for it it is noticeable, otherwise it can be accepted. The Ratio sides were the only kit pieces used, the rest went into the “it might be useful one day” box.

Now, unfortunately as I made the set some years ago, I cannot remember which bits of the sides I used and how they were arranged together, and I am very pleased to say that it was very difficult for me to try and sort out the cut and shut joints.

I did not notice at the time I was building the coaches that the Smoking and Non Smoking compartments had different door bonnets so I have not incorporate this feature.

Latter on I would like to add the little blue boards with 'SMOKING' painted on them in white lettering.



Trailer - end view

The new ends were constructed from 040" ABS sheet, with the mouldings and the driving end details like the destination light cover stuck on to them. At the same time the tumble home on the ends was eradicated.

The CP coaches had separate compartments, unlike the SL coaches which had an open seating arrangement with a corridor to allow for rapid loading/unloading.

The separate compartments partitions, when fitted, make for a very rigid structure. Again these were made from ABS.

The interior followed the normal colour scheme of blue for First Class and Brown for Third.

The arc roofs were rolled by the traditional method on the carpet from thin aluminium sheet, just like the prototype, (the aluminium that is, not the carpet bit).

This is not me adding fine details, but I happen to have a sheet of aluminium that can be worked with a craft knife and a pair of toe nail scissors. It produces a very robust roof. For internal

strengthening of the roof against twisting, a formed balsa wood liner was glued in place. There is very little roof detail as the Brighton Management were worried that, if an HT cable broke, it would snag on things like the roof ventilators. The detail that there is can best be taken from photographs. The dropped end on the roof was formed from two different rolled roof profiles and car body filler.



Motor coach - side view

The buffers are Oleo Pneumatic ones available from Roxey Mouldings. Screw couplings were fitted, but at a later date I will replace the centre ones with a bar coupling.

The unpowered bogies are Ratio Fox Lightweight, as found on their LNWR coaches. I cannot remember where I obtained the plastic sides for the motor bogie unfortunately, however the bogie,



Motor coach - driving end

is a Tenshodo WB 31.

To fit the sides I found it necessary to dismantle and reassemble the bogie to get everything working properly.

A snag then appeared. The bogie is of snap together construction and the plastic clips become tired. This allows the assembly to become slack and the meshing between the worm and wheel fails and the plastic worm wheel strips. Spares are available, but of course one has to strip down the mechanism making everything loser. I overcame this by bending up two 'u' shaped clips from 1/16" welding wire with an interference fit to firmly hold the structure together. These were fitted on the ends of the bogie.

Some of the coach floor had to be cut away to accommodate the bogie, not a serious problem.

The massive underframe on the Motor Coach was a bit of fun. I copied the drawing and taped it to a suitably long piece of 040" abs. With a scribe I

carefully pierced the paper at the corners and carefully by eye at the centres of the lightening holes corners. These were drilled and cut where appropriate and fettled with a needle file. I have not yet fitted all the underframe detail but that will happen one day.

The finished bodies less glazing were cleaned up and spray painted with an etch primer suitable for metal and plastic. This is obtainable from car accessory shops. It is easy to apply and provided

that you do not drench the surface with it, it shows no runs. The finish was Mexican Brown, for the sides and silver for the roof, again car sprays, and Woodham Wagon Works transfers were appropriately applied.

As soon as they were dry a thin coat of varnish was applied to each one to protect it. Unfortunately the door that should show 'DRIVER' shows 'GUARD', as there are no appropriate ones available

I am still at a loss on how to model the collector bows. The surrounding wire mesh protective fence was constructed with the mesh from a domestic sieve, using mesh as fine as I dared that would not be clogged with paint. It still clogged a bit.

Well that is a short description of the construction of the set. It gave me a lot of pleasure in it's building, and I am pleased to say that it runs well. The compromises that I had to make have quickly been forgotten and I am pleased to say that the coaches stand up well against period photographs.

It is a fact of life in my little world, however, that as soon as I scratch build a model of something unusual a commercial company produces a RTR version. I wait to see.

All photographs copyright Eddie Carter

[Index](#)

Bricklayer's Arms Coke Shed 1844

Or a “*reservoir for feeding engines*”

By Chris Cox

The Bricklayers Arms Extension Railway was a reaction to the London & Greenwich Railway's monopoly on the South Eastern route into London. Opened to the public on the 1st May 1844 it successfully forced the L&G to re-think the exorbitant tolls charged for the use of their elevated railway into London Bridge Station. Passengers still had to catch a horse drawn carriage into the city and as a result Bricklayers Arms regular use as a passenger station rapidly diminished, with a reduced passenger service continuing until 1852 when the SER diverted all its trains to London Bridge and the station closed to the public.. However, it's subsequent growth as a goods depot and engine facility was rapid; even by 1847 the site had changed dramatically to reflect it's increasingly important role in handling the significant goods traffic from Kent and the South East. At the time of building, the Brighton, Croydon and Dover Railways had formed a Joint Locomotive Committee to pool their mechanical resources. In April 1845, owing to continued operational difficulties, the Brighton and Croydon companies withdrew from the arrangement, allowing the South Eastern to go their own way. In 1846 the Brighton and Croydon amalgamated to form the London, Brighton & South Coast Railway.

An excellent description of the layout at Bricklayers Arms was given in J. Mead's; *'The Illustrated Guide to the London and Dover Railway'* and a well known if somewhat exaggerated illustration graced page 285 of the *Illustrated London News* of May 4th 1844. The buildings were designed by Lewis Cubitt, who would later design the imposing façade of Kings Cross. The contractors were Grissell & Peto. Bricklayers Arms was a massive site covering some 26 acres comprising a huge goods shed, a large carriage shed, which was part of the extensive station, locomotive shed and turntable, and a *'coke depot and reservoir for feeding engines'*. This last building is the subject of this article, being the first in what I hope will be a series covering all the buildings, culminating in an exhibition layout set during the height of the first 'Railway Mania'.



Simple elevations of the principal buildings and the general track layout at Bricklayers Arms, were illustrated by Samuel Brees in his extensive work; *'Railway Practice'* published in 1846

The coke shed or “depot” was shown only as a rear elevation, cross section and one end view. We will probably never know what the other side looked like, so I have chosen to model it as open arches in keeping with the rest of Cubitt’s style for the site. This also affords the viewer a better look inside the building.



The decision to model Bricklayer’s Arms in 1844 is based on several factors. For some time I had been looking for a suitable prototype to model, which encompassed my passion for the early days of railway development and the fascinating story of London’s early railway history. Fellow Brighton Circle member John Minnis, to whom I am very grateful, hinted at the striking selection of buildings on offer at Bricklayer’s Arms and so it was chosen.

2mm Perspex sheet was used for the main shell of the building. I find this a good base to work from, as the Perspex is strong, light and does not distort under the influence of liquid poly, unlike styrene sheet. This is particularly important where several layers of embossed brick styrene are



to be added, each one potentially 'pulling' on the main structure. The Perspex was carefully cut to size; door, window and arch apertures cut out and then pieced together using poly cement. Embossed Flemish Bond brick styrene was cut and overlaid on the Perspex with the appropriate arches and apertures cut out. Layers of brickwork were then built up and the arches cut and added from 15thou plain styrene. The

bottom few courses of brickwork were rendered with Milliput and the detailing in the stonework added from styrene.



After searching for suitable window frame etches and finding nothing to fit, I decided to cast the frames from whitemetal. A master was soldered from brass wire and sanded flat. A Swiss file was used to ensure each window pane was square. The frame was then included in a mould for a W. B. Adams luggage break van (that's another story) and the windows were cast. I find the cast frames have better 'weight' to them than the rather flat etched

versions. Each window was then painted and glued to clear styrene sheet, trimmed and individually fitted to each window aperture. This process was a pain in the anatomy and will not be repeated on the other buildings, the Perspex of the main structure will be used to form the glazing.



Having detailed the interior with coke trucks and hoists (yet to be fitted), I felt a removable roof was desirable. Therefore some attention was paid to the roof timbers. The trusses were cut from 2mm thick plywood, as were the purlins and ridge board. The whole structure sits on small brick piers and three cast pillars; the master for these was lathe turned from brass rod and included in the same mould as the window frames.

According to a detailed article in the 'Civil Engineer & Architects

Journal' of 1844, the roof covering at Bricklayers Arms was '*Queens slating*'. These were very large slates measuring 34" tall x 20" wide. At first glance they look a little large on the model but are nevertheless correct. These were scored out on thin card and laid in strips. The lead ridge is thin paper over a cocktail stick. The whole was then painted in a blended 'slate grey' and dry brushed with a paler blend. A good many joints were picked out with a well-thinned dark grey



and when all was dry, each slate was burnished to a greater or lesser degree with a polished tool made from the head of a small screwdriver. This process allows each slate to take on an individual patina and creates the very slight sheen associated with new slate (and, curiously, is not as boring as it sounds). The completed roof simply slides up and out through the convenient gap in the wall capping at the base of the chimney, the front first and the back follows. The

smaller office roof was the first attempt with slates laid individually. This looks a little too rustic but my excuse is that since the last building to be erected at Bricklayers Arms was the coke depot, they were simply using up the 'B quality' slates!



The water tank posed a few problems as the original illustration is ambiguous, to say the least. I decided on a representation of wrought iron plate construction with double riveted strips over a butt joint. In model form the tank is formed from 15thou brass sheet and the rivet strips made using an old sharpened clock gear rolled along a strip of thin copper sheet. This provides a perfectly even rivet spacing although it is very difficult to keep the double row of rivets either in line or offset. The

strips are then turned over and soldered in place. The water crane is a copy of that illustrated by Brees for Tunbridge Station circa 1846. Scratch built from brass rod and scraps, the operating mechanism was very slightly modified from the drawing so that the crane can be swung out of the way of passing domes, chimneys and engine drivers heads!

Rainwater down-pipes were made from brass tube cut and bent at the bottom to point out, brackets and rain heads from scrap brass. I find the waste material around the edges of etched brass kit frets very useful indeed; don't just bin them, you never know when they might be useful!

Painting the building was daunting as I had never tackled London stock brick before but



strangely it was relatively easy. I stick to good old Humbrol matt enamel paint, preferring to blend, wash and dry brush these more than anything else, so the whole building was painted in a base coat of Humbrol 121 and then dry brushed with a blend of 94, 154 and 62. Shadows and

odd bricks were picked out in 62, and the stone is 121 with shadows picked out in a blend of 121 and 98, with a dry brushing of 108 for highlights. All metalwork was painted in a very useful Humbrol 67 'Tank Grey', dry brushed with a lighter shade. I have discovered over the course of this project that one should never paint anything pure black or pure white, as the effect of scale on colour renders everything a muted tone; the stark paint straight from the tin can look much too intense. Initially I used black to dirty the brickwork above the tracks - until a friend reminded me that coke is an almost smokeless fuel and the sooty deposits looked quite out of place. Needless to say they were tactfully removed!



The completed model will be well bedded in to the layout, with block paving around and between the rails and a number of extra details, such as a barrel to collect the drips from the water crane and a wheelbarrow and broom to collect the spilt lumps of coke. I have yet to decide whether to introduce the ubiquitous London pigeon to the chimney tops!

I would like to thank John Minnis, Jim Greaves and Geoff Smith for their help and encouragement in the research undertaken for this project, and Eric Gates for the opportunity to prattle on about it!

All photographs
copyright Chris
Cox



[Index](#)

LB&SCR Cowens Sheldon Crane and Tender

By Barry Luck

Photo 1 shows the completed D&S crane (built by Chris Luck), together with its scratchbuilt tender (built by Barry Luck).





Photos 2 and 3 show close-ups of the tender, built from the only known works drawing of this vehicle. As there are no clear photos of this wagon, the lettering has been assumed from photos of other crane tenders, for example those shown for travelling cranes in 'Southern Wagons Volume 2'.





Photos 4 and 5 show a tender built by Charlie Trace, from photographs. The two vehicles are approximately the same dimensions, but with differing detail – the cradle for the crane jib, the positions of the toolboxes, and the step at the left-hand end of the vehicle. This step is clearly visible on one of

the Cocking accident photos, but is not shown on the works drawing. This begs the question of whether the works drawing is 'as-built'; whether the step was added later on, in service; or whether perhaps there were two tenders over the years?

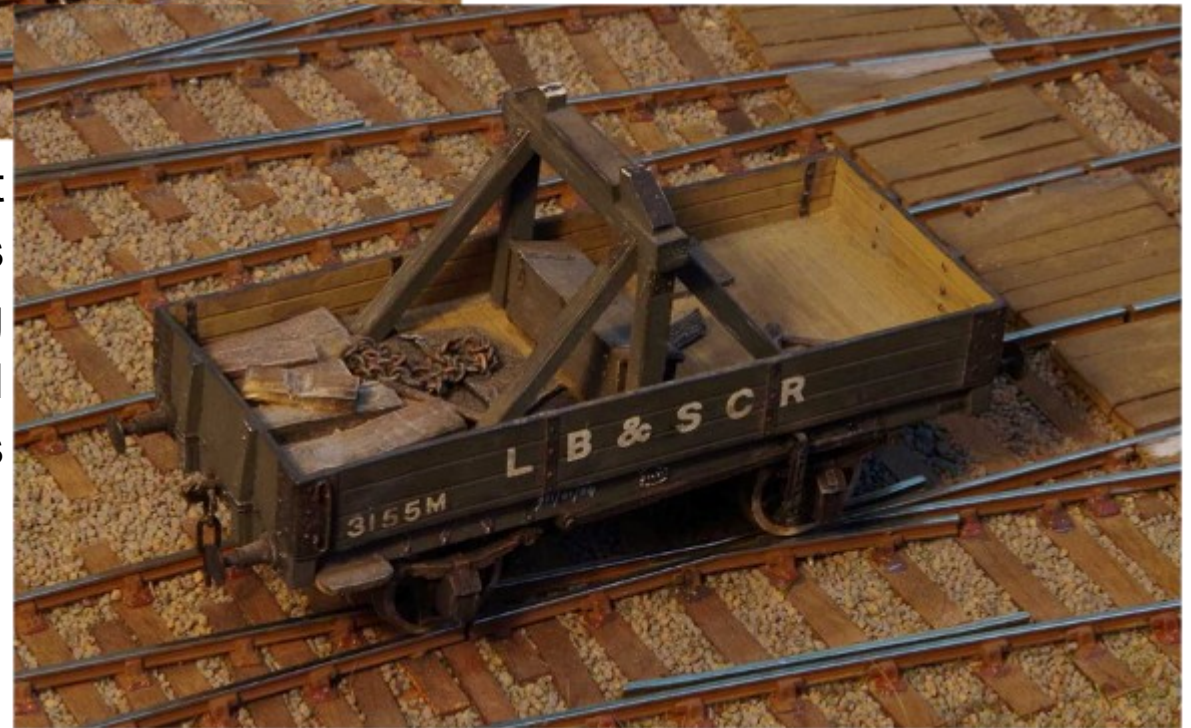

Photo 6 shows the complete breakdown train, consisting of two Chatham kits brake-vans, a Roxey Stroudley coach, and a scratchbuilt wagon and van, together with the crane and tender, departing Plumpton Green towards London.



All photos copyright Barry Luck

[Index](#)

Open A wagon A4878

By Simon Turner

Yet another Brighton 5 plank wagon, but this time with a low round end, only one plank higher than the sides.

“Open A” designated all 5 plank opens, which were the typical Brighton open merchandise wagon. As such, they would be seen widely on other pre grouping companies’ networks.

Built in 1876, this vehicle features a single block brake and a simple wooden bar to support a wagon sheet. Note the absence of diagonal strapping on the wagon sides and the washers, rather than washer plates, either side of the doors.

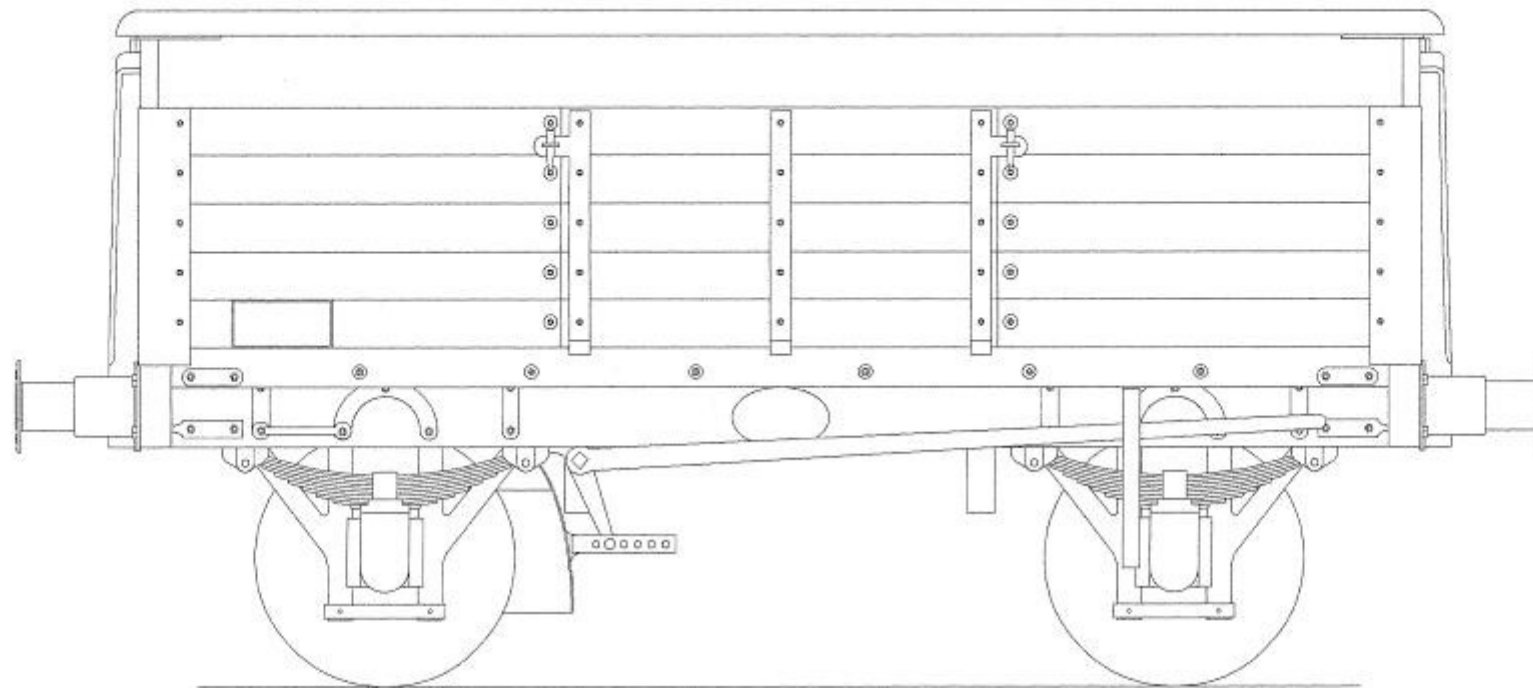

LB&SCR A class Open Wagon
As per No.A4878 built 1876

Drawn by S.T.Turner May 1998

A4878

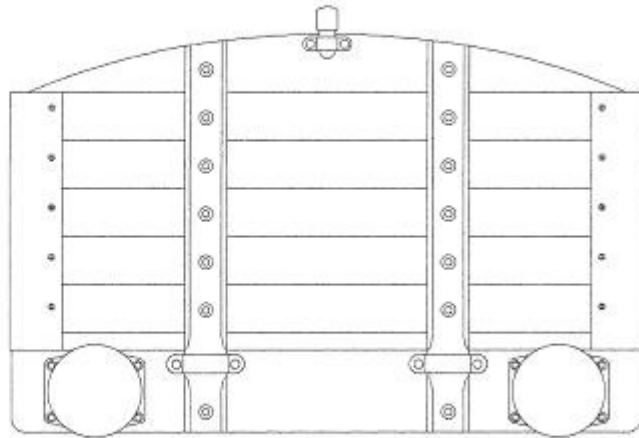

End View
Wagon No.A4878
Drawn by S.T.Turner May 1998

A4878_E

H2 Atlantic in 7mm scale

By Graham Boseley



H2 number 424, in Marsh livery. It was later named Beachy Head and a replica is being built at the Bluebell Line. This is a Gladiator kit with Slater wheels and motor and gear box from ABC. It was built by Geoff Brook and painted by Colin Tyler who took the pictures. Both are members of our club and Colin is a professional painter.



Left, a view of the cab.

Right, the interesting challenge presented by 6' 7½" drivers at 6' 10" centres.

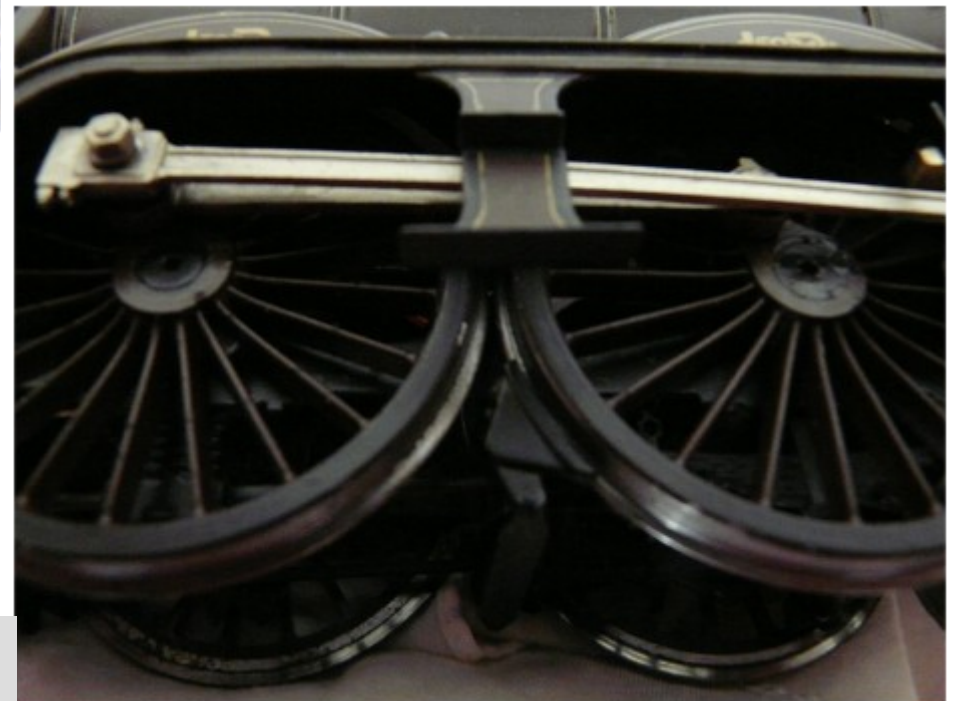

[Index](#)

Photographs copyright Colin Tyler

Vintner's Yard, LB&SCR - EM Gauge

By Eric Gates

Vintner's Yard is one of those corners of the LB&SCR, which have been invented for modelling purposes. In this case, it is a small yard, somewhere in South London, in an area in which members of the Worshipful Company of Vintners have their warehouses. By one of those odd coincidences, two of the regular shunting locos are E tanks, Bordeaux and Burgundy.

The layout was designed deliberately as a small shunting yard, so that I could prove to myself that I could build and operate a model with slow speeds and working Alex Jackson couplings.



I have previously built a tennis racquet shaped test track, which is fine for watching the trains go by, but does not really test slow running or smooth trackwork.

The development of the layout is described in full gory detail on [RMWeb](#), and I will not revisit the various distractions that caused a “quickie” retirement project to take 5½ years. Sufficient to say that the sudden incentive to get things finished was an invitation to show the layout at the annual RMWeb members’ day meeting at Taunton. This caused the final push to iron out bumps on the track, make couplings actually work and add a population to the scene.

The scenic area is 4 feet long, with outriggers to provide fiddle yards at either end. This allows cuts of 3 wagons plus a loco and brake van to be handled. Trains arrive from the centre road on the left hand side and the loco runs around using the cross over, the rear left hand exit and then the fiddle yard. Notionally, there is a siding at the rear for supplying the various





warehouses, a through road exiting at the right hand side, which leads towards the docks and is used by Grande Vitesse vehicles, and a spur back to the left, which serves a gas works.

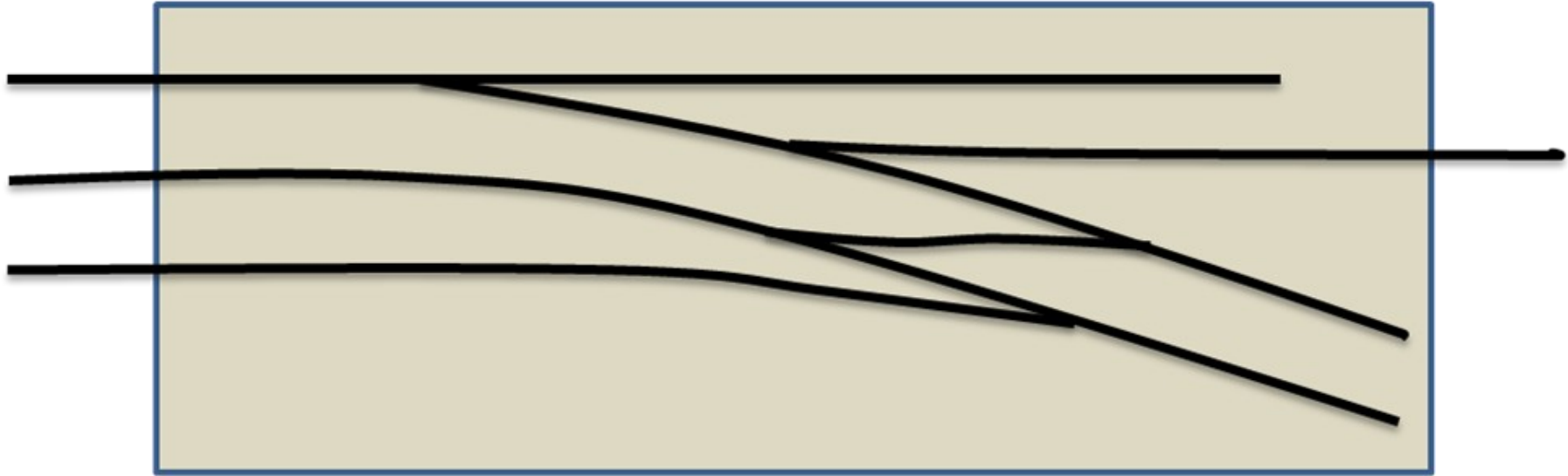

The headshunt to the right front is just long enough for an E tank and 3 wagons, allowing a cut of coal wagons to be shunted into the gasworks and empties to be removed. Don't try it with a tender loco!

The locos that are currently available to use on the layout are listed below. However, one of the aims of Vintner's Yard is to create an environment in which I can tune some of my other locos, so that they work to a reasonable standard.

Burgundy - Albion kit built by Karl Crowther

Bordeaux – SEFinecast (or possibly Wills) built by Karl Crowther

C class – EBM kit, built by Mike Waldron

Craven 0-4-2 saddle tank – from etched parts by Ian White

Piccadilly – GW Models

Rolling stock has been collected over the years and consists mainly of examples from 5&9 Models, Woodham Wagon Works and a number of other suppliers of early vehicles.

The precise period in which the layout is set remains slightly vague. E tanks suggest that it might be around 1880, but a couple of earlier locos are also available. Figures

might be slightly earlier although the range of Victorian (rather than Edwardian) figures is rather limited. Again, 5&9 products feature.



For me, the major learning point from this layout has been the need for “system integration” of all the various elements. If you are building track, locos, rolling stock and couplings from kits or from scratch, somehow you have to get them all working together.



And if the layout does not work properly, you can spend a lot of time trying to work out if it is the loco or the track or the rolling stock that is at fault. In this case, readers may have noticed that Karl Crowther and Mike Waldron have been responsible for three of the locos. Both build very smooth running chassis and I have therefore assumed that, if any of these three locos have a problem anywhere on the layout, then it must be something wrong with the track. There were a number of places at which plastic chairs needed to be reset to get smooth running. There is at least one turnout where the locos visibly hobble over the gap between the crossing V and the switch rail, but I am afraid that one is beyond salvation and as long as they can cross it, I have put that one down to experience.



You might assume that rolling stock would follow automatically, but it became evident that I had set the wheels very tight against the back to back gauges. Backing them off very slightly solved almost all the problems. Alex Jackson couplings add a whole new dimension, as you not only need to bend up the wire with a degree of precision, but ensure that it sits in a fairly small “bubble” of space just beyond the line of the buffers (strangely, nobody seems to produce a jig for dumb buffered wagons). Slackness in the fitting of the wheelsets to the bearings, excess wobble in the suspension and soldering the end of the coupling to a rocking suspension unit (learned the hard way) can all spoil your day. Add to that the positioning of magnets and the strength of the

magnetic iron droppers which need to be set so that they operate together. Once you have a formula that works, it should be relatively easy to reproduce: getting the formula right in the first place can involve some quite frustrating trial and error.

None of this process is particularly photogenic – unless you want a picture of the author with an expression of exasperation, resorting to a stiff drink. The photos merely tend to show the pretty bits, with



no evidence that it all works. I still have a lot to learn about building a free running loco chassis; the Craven saddle tank is not too bad, although it does sound a bit like a coffee grinder in one direction. And there is clearly a black art involved in getting the weighting right on a single, so that it can pull its own tender – far less anything else. Fortunately, I have plenty more loco kits on which to practice and, hopefully, one day, I will feel that I have got one to the standard that I would like.

All photographs copyright Eric Gates

[Index](#)

Belgravia - 7mm scale

By Peter Smith



I have just about finished my 7mm 'Belgravia', built from EBM etchings, and although I say it myself, she's a beauty. She runs quietly and smoothly and I'm looking forward to seeing her pulling a train on Saltdean; that will not be until August at Southwold show, unfortunately.

If anyone else is thinking about building one, there are a few points that are worth mentioning. Slater's do the correct driving wheels (I wonder how many of those they've sold over the years!), and I used them but with hindsight something a little smaller would have been better because with overscale flanges the clearances inside the splashers are non-existent, which is why my loco

body sits a bit too high. The problem is that you can't get a slightly smaller wheel with the extended axle for the outside cranks.

If I was building her again there is one thing that I would certainly do, because doing it once the body has been assembled is a real pain. The boiler/firebox has too much metal that comes right



down inside the splashers; the way to sort this out is to put the boiler in place and draw around the splasher tops with a felt tip, then remove the unwanted metal with snips before soldering the boiler in place.

This gives much needed clearance for the wheels and more space for the motor. It's quite possible that Mike mentions this is in the instructions, but as I only used the diagrams I wouldn't know about that!

The biggest problem is the underhung springs on the driving axles. If you fix them to the loco you can't remove the body, but they have to be secured well enough to stay in place. There's very little room between the wheel and the cranks and at the moment I've chickened out and simply left them off. It bugs me though, I'll have to find a way of fitting them eventually.

My loco has a Slater's motor and gearbox, for which there is ample room, and there are no pickups; she collects current on the loco on one side and the tender on the other with an insulated drawbar. A Zimo sound decoder with SR generic 2 cylinder steam sound, and she was ready for the road.



I decorated her in my usual manner using printed paper shapes glued in place...the only yellow paint is on the dome and the wheels. She looks a bit bright in the pictures because the sun was streaming into the room but the actual colour is less luminous.

I'm delighted with her, so many thanks Mike for looking after us 7mm modellers so well.



Photographs
copyright
Peter Smith

[Index](#)

Signals for Newick & Chailey

By Phil Taylor



I have just completed the full set of running line signals for my 4mm scale Newick & Chailey project; the ground signals are yet to be started. I don't claim to be any kind of signal expert, all my knowledge has been gleaned from books and magazine articles – I hope the Circle's signalling experts won't find too many faults!

The signals are all of the slotted post variety, for the late 19th century period, and were made using a rare old mixture of parts from MSE, Mike Waldron, Colin Craig (ladders), Masokits (cranks etc.) and a fair bit of scratchbuilding and detail enhancement. They are operated using the Davin Bouncer mechanism as described in *MRJ* No. 67 (1993) and actuated by memory wire. The lamps also work, using bi-colour red/green LEDs.

Details were gleaned from photographs and Mike's notes, together with the very useful article from the September 4, 1941 *Model Engineer*, which seems to be the only published source of LBSCR slotted post signal

Photo 1, Up Starter

A standard simple signal of the period, tall for sighting over the station footbridge. The Down Home (not illustrated) is identical.

drawings. Photographs do not exist showing all of the actual signals, however there is enough detail in the background of pictures of the station, together with pictures of other stations on the Lewes and East Grinstead Railway in the period in question, to be confident of the design of each signal.

This article describes and illustrates their construction and operation.

Photos 2 and 3, Down Starter with high level rotating shunt signal

Left - This signal had two ladders, one each side, which can be discerned from the prototype photograph.

Right - Pictured from the reverse (south) side. The two ladders are more clearly visible, as is the shunt signal operating mechanism.





The first signal to be made was the Up Distant. During construction, I made a careful note of each stage, to allow the remainder to be built as a batch and reduce the thinking time and risk of mistakes. There are 71 separate main steps, which I don't propose to detail here!

The arms and slot boxes are from Mike Waldron's etches.

The posts are MSE white metal, mainly because I had them in stock. I don't consider their relative lack of robustness an issue, because an impact with an elbow or clumsy mitt will probably result in writing off the signal in any case! It was necessary to cut channels down the side of the posts for the wiring to the LEDs. I used lacquered fine copper wire salvaged from an old 12V motor, superglued into the channels, and then filled and smoothed off. I cut small diagonal holes through the post at top and bottom of each slot so that the wire could be tensioned to persuade it into the slot as far as possible. Out of all the signals, each with at least two wires, I had only one failure where a short circuit developed between the wire and the post, where I had to cut a new slot and start again. It would have been far easier to use hollow tube and feed the wires inside...

Photo 4, Up Home with Subsidiary Arm

The lower arm is used to allow a shunt move into the down platform in the northerly direction.

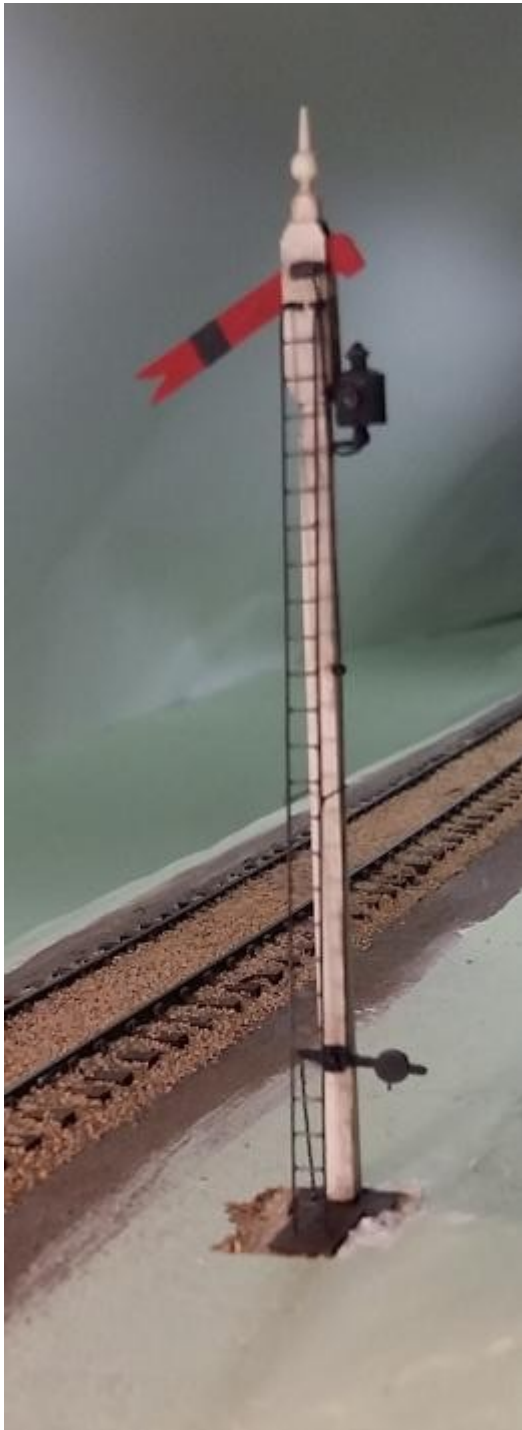

For the ladders, I wanted something a bit more refined than a flat etch, so I used Colin Craig ladders built up from etched stools and brass wire steps in a simple jig. The process sounds horrendously fiddly and difficult, but is actually fairly easy and satisfying and results in a superb looking ladder. The very long ladders were made by joining two sections together end to end, with butt joints staggered for strength. The lower end was soldered to a base plate soldered to the signal mounting tube, which will be buried under scenic treatment eventually.

Photo 5, Up Distant

The large scale map shows this signal on the east side of the line, which implies that the arm would, unusually, have faced the trains. I have never seen any photographic evidence to confirm this, but I assume it would have been to aid sighting on the curve at the exit from Cinder Hill tunnel. The (cosmetic) operating chain can be seen leading down from the left hand end of the balance weight lever – this is made from fine twisted wire and simply passes through a hole in the base plate. The cosmetic chain wheel will be located next to this when I get around to fitting the signal wires! The actual operating rod, below the balance weight lever, is painted light grey in an attempt to disguise its existence, by luck quite effective in this view.

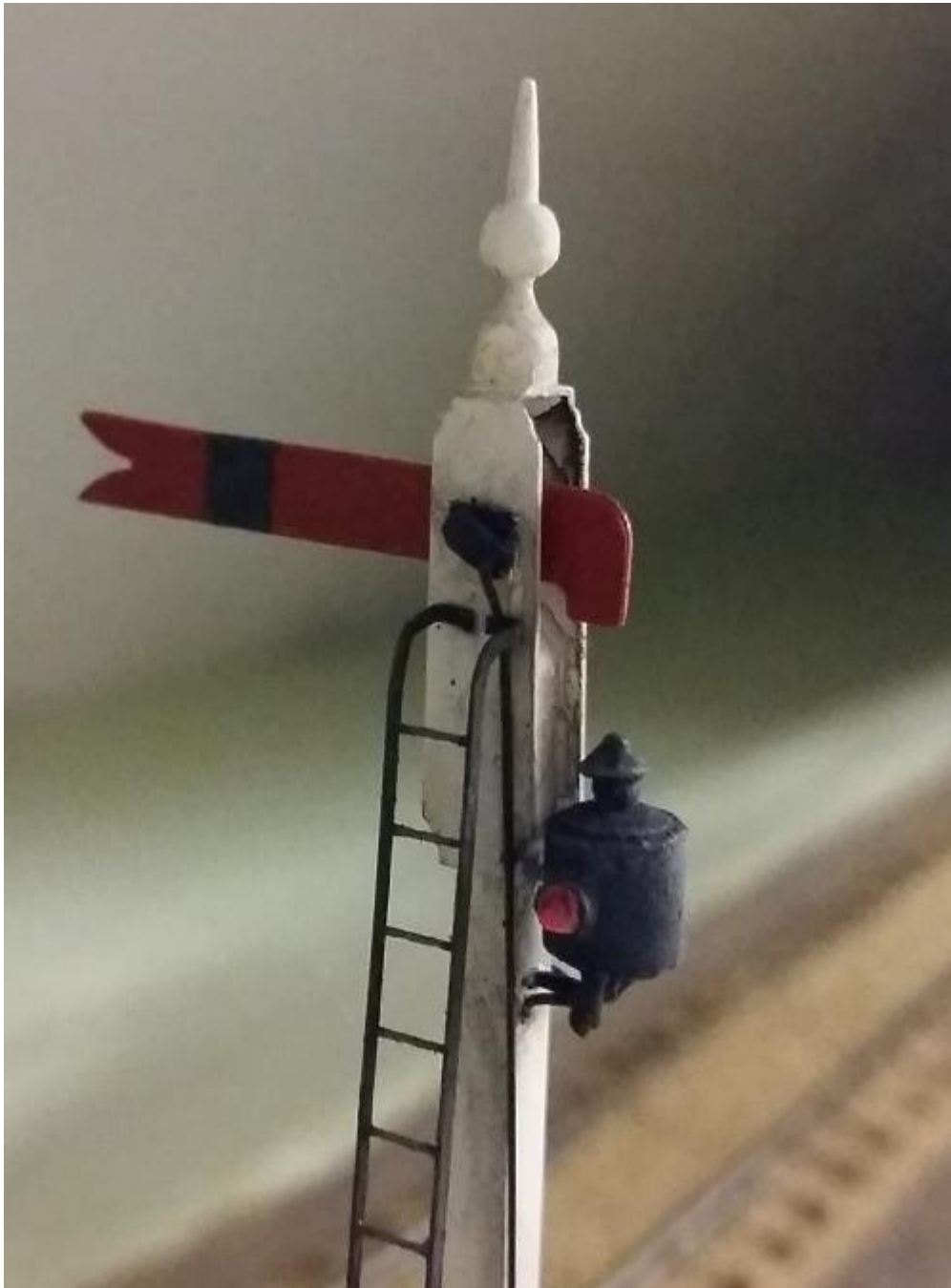

Photos 6 & 7 Up Distant on and off with the lamp illuminated.

The lighting was one of those very rare areas where the LBSCR actually makes it easier for us modellers! On the real lamps the change between red and green was effected by internal moving coloured glasses so there was no external movement evident, just the change of colour of the light. This can easily be achieved with a red/green bi-colour LED, although the actual colours are unlikely to be accurate. I use a voltage regulator circuit to supply about 2.2V, which gives a fairly soft light. If the colour shade bothers you, maybe an experiment with translucent paint over the lens may yield a better result. The LEDs are 3mm diameter, and fit into a scratchbuilt lamp case made from turned brass tube, drilled the appropriate diameter and counterbored to fit the lip at the lower edge of the LED (which is a fractionally smaller diameter than the outside of the lamp case). A small piece of tube for the lens holder was cut to size and soldered to the front of the lamp case, with a lens turned from clear plastic salvaged from ancient Airfix model aircraft sprues – it doesn't seem possible to buy small diameter clear plastic rod. The back lens sits in a much smaller hole which was just simulated using a drop of PVA, which dries fairly clear. The lamp lids were cut from MSE Saxby & Farmer signal lamps (ref. SC0014) and Araldited in place. The LED supports the case, and is held in place by passing the common leg through the post and soldering in place, which also provides the return current path.

The signal operating rods are from 0.3mm straight brass wire, passing through Alan Gibson's very fine handrail knobs. As I wanted to incorporate bounce, with a smooth and realistic action, it was vital to eliminate free play and friction wherever possible. All holes were reamed to be a close running fit using a tapered broach, and the wire passed straight from the actuating rod (of which more later) to the arm lever. The balance weight is actuated by a small piece of 0.3mm wire soldered to the main wire, bent through right angles and passed through a hole in the balance

weight lever, thereby avoiding any lost motion to the main arm.

The Down Starter incorporates a high level rotating ground signal for entry to the goods yard. This rotates around a fulcrum at the lower edge of its (non-working) lamp, and is driven by a fiendish arrangement of rods and cranks, trying to replicate the prototype mechanism seen in the photograph published in the Brighton Circular Vol.34 No.4 page 159. It does manage to rotate the signal though very nearly 90 degrees - I didn't bother with bounce in this case....

Mounting and Operation really belongs in a general modelling publication as it is not Brighton-specific, however some details follow.

I decided to mount the signals using concentric circular tube, to allow fine adjustment of the exact alignment of the signal. The outer tube (which has the LED current return wire soldered on beforehand) is Araldited into a slightly oversize hole drilled in the baseboard, its vertical alignment being obtained with a simple jig consisting of a piece of brass bar turned to be a close fit in the tube, screwed to a substantial steel plate which is weighted to rest on the adjacent track and holds the tube truly vertical while the glue cures.

The LED red/green feed wires, together with the signal operating rods, are located within the inner tube, to which the post is soldered to act as the LED common return. The act of plugging in the inner tube to the outer one when putting the signal in place completes the return circuit.

The below-ground operating rods consist of 1.0mm diameter brass rod, cross-drilled 0.3mm near the top to take the signal operating rod when bent through 90 degrees, passing through a substantial close-fitting plug soldered into the inner tube, flush with its lower end.

Photo 8 The Davin Bouncer mechanism and memory wire actuator, mounted on a piece of board which is screwed to the baseboard under side. To the left Mike's etched bouncer mechanism is visible, with the memory wire and return spring below it. The horizontally-swinging lead weight which is such a clever part of the Davin design is prominent top centre. At the far right edge is the operating crank for the signal – the signal's operating rod is a smooth close running fit between the two prongs protruding from the edge. The exact amount of travel can be varied by moving the connection up or down the vertical limb of the crank, while the length of the connection can be fine-tuned by adjusting the screw seen at top right centre. The bounce itself is modified by adjusting the screws at each side of the bounce mechanism, centre left. Once satisfied with the operation, the position of the screws is locked by a drop of PVA or TippEx.

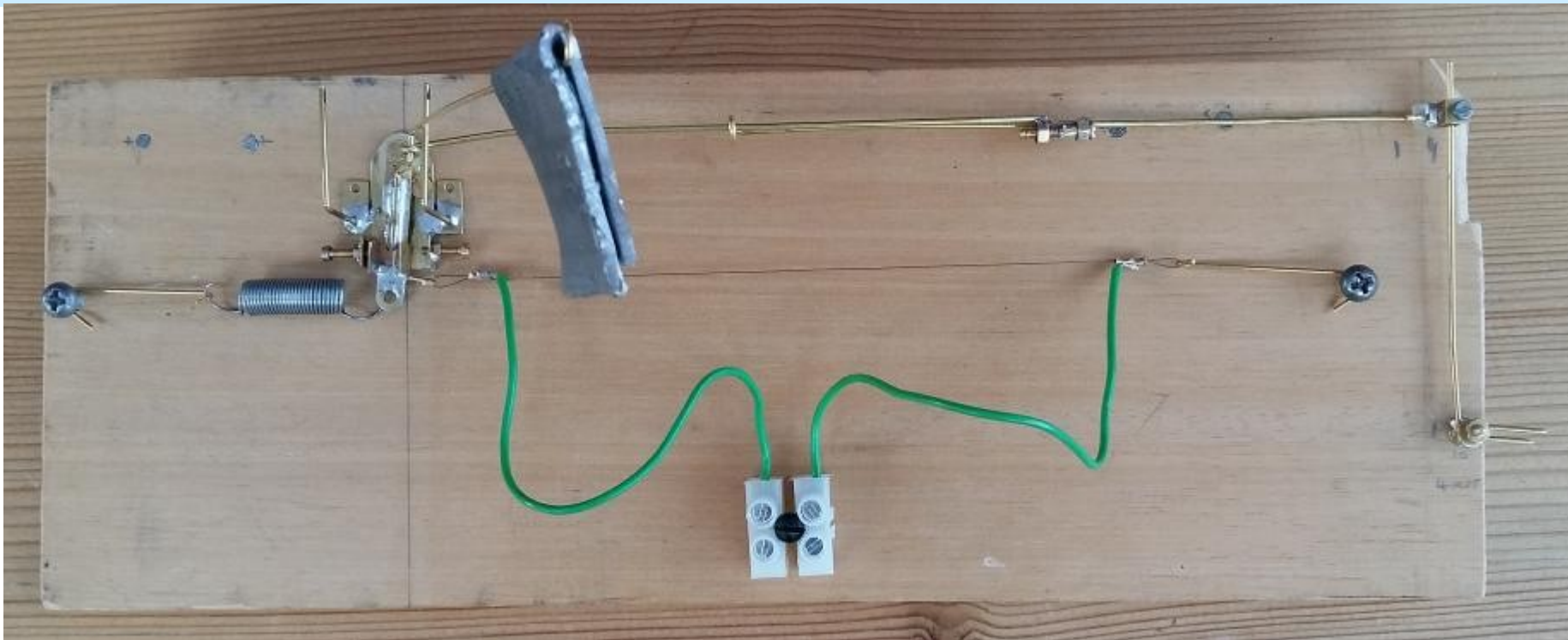
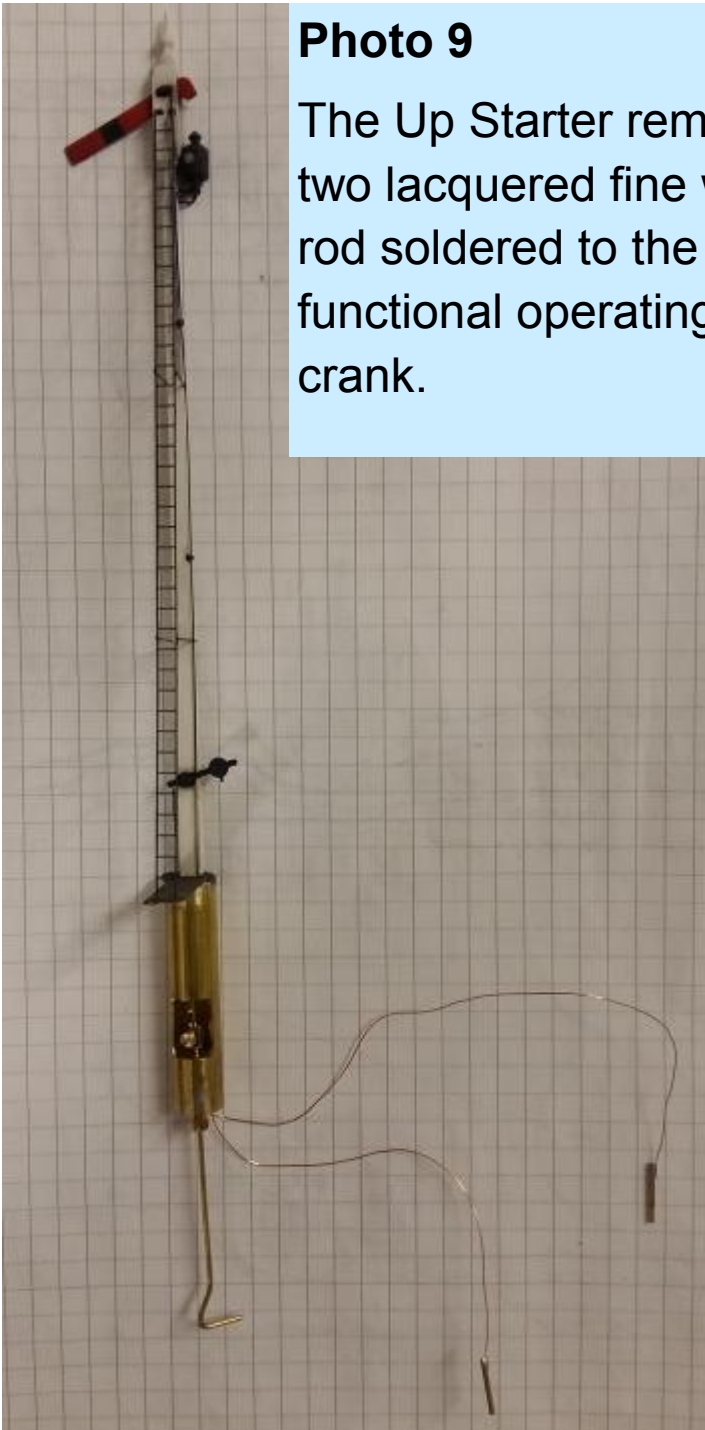

Photo 9

The Up Starter removed from its mounting, showing the below-ground parts. The two lacquered fine wires connected to the LED can be seen (with a piece of brass rod soldered to the end to aid connection through a choc block), as well as the functional operating rod, with its horizontal section which engages in the operating crank.

The travel of the operating rods is limited by relatively substantial stops, grub screwed to the rods and constrained by the soldered plug. Access to the upper stops is via a hole cut in the inner tube. The bottom end of the rod is bent through 90 degrees with an offset to allow it to pass through the outer tube when mounting the signal, which engages on a crank attached to the bouncer mechanism. In this way the delicate mechanism above ground is protected from abuse emanating from below ground....

I really wanted to achieve a fluid and realistic bounce mechanism, which replicates the prototype's mass, with a slow pull to 'off' without bounce, and a nice undamped bounce back to 'on'. Having observed many attempts to achieve this at exhibitions, I came to the conclusion that the Davin Bouncer had



the most potential. I have used both the original scheme described in *MRJ*, and Mike Waldron's etched version: both work well. It is possible to tune the amount of bounce in both directions by adjusting the end stops. The mechanism is actuated using memory wire driven by a simple 'constant current' circuit. This is reliable, cheap and silent in operation. As the vertical movement of the signal operating rod is so small (about 1mm), it is necessary to provide fine adjustment of both the amount of travel and its end points, while eliminating all extraneous free play. The bounce movement of the operating rod has to match the actuator movement exactly otherwise the fluidity is lost. It goes without saying that all moving parts have to fit well and be carefully deburred etc.

The signals are operated by microswitches driven by an MSE lever frame, mechanically interlocked by mating it to a modified Modratec locking mechanism, as I described in an article in *MRJ* No. 179, 2007.

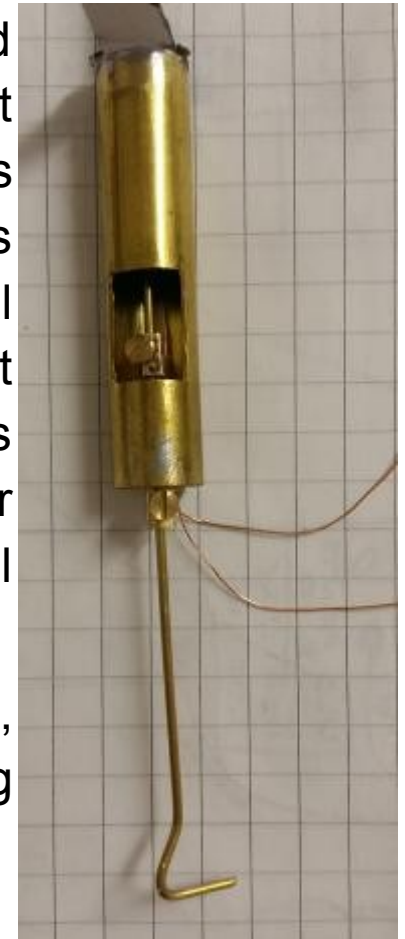

Photo 10 Close up of the inner tube section. The upper and lower stops are visible – between them but not visible is the soldered plug. The position of the stops can be adjusted until the on and off positions of the arm are exactly right – lower edge of the arm horizontal for on and a quite shallow 22.5 degrees (along the arm centre line) for off. The fine electrical wires are routed at the back of the tube so as not to foul the moving parts and fed through a groove in the plug, then Araldited in place. There is room (just) for two operating rods, but something like a large gantry or bracket signal would require a different approach!

All photographs copyright Phil Taylor

Postscript

Since writing it, I have devised a better method of connecting the signal operating rod to the bouncer operating crank. The bent section of the rod is replaced by a paddle (from thin scrap etch) soldered on, with a 1mm hole. Only one short leg of the operating crank is then required, which fits in the hole.

Illustrated in the photo to the right.

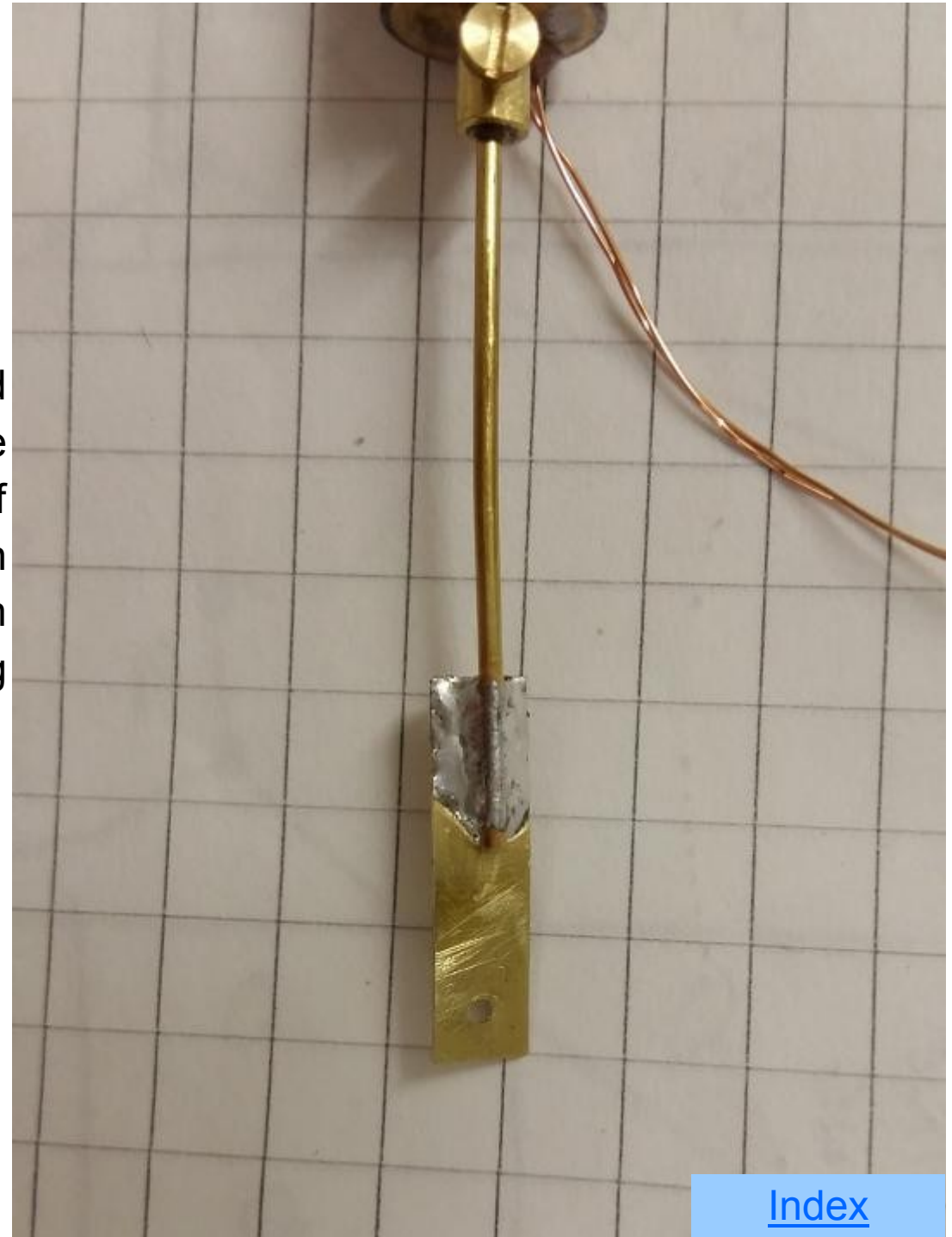

Goods Department 10 Ton Travelling Hand Crane No.19

Part 2: Scratch building the Crane's Underframe in 7mm

By Colin Paul

As described in Part 1 (Digest No.2, page 17), the construction of No.19's Match Truck, was pretty much straight forward. Barring the W-iron etch (www.mike@mjwsjw.co.uk), leafsprings, and oil filed axleboxes (Philip Elverd), virtually every other item had to be scratch built. No commercial castings or etches are available either for the Travelling Hand Crane which makes construction a lot harder i.e. in how to design and fabricate the individual parts. So far this particular model has been a lot more challenging, difficult, and time consuming. I am basically constructing a "one off" model from scratch, and working from a few photos, which is hard to accomplished successfully as many fellow Brighton modellers will well know. I am also going in blind, as I have never constructed a crane before. Scratch building a locomotive for instance is child's play compared to this particular project. At first glance, the underframe looks simple enough, but it isn't. It's a lot more complicated than first envisaged. For me personally, things have moved on though in leaps and bounds in the last six months or so since work started with the help of CAD drawings and 3D printing, in particular the large gearwheels, pinions, axleboxes, leafsprings etc. which came from Francis of www.3d-companions.com, and some other items from www.shapeways.com, the latter of which also came from drawings supplied by Francis. Through his invaluable help, he was instrumental in preparing and drawing the completed virtual reality moving crane body for me (a more detailed article on construction of the crane body will be in Part 3). If it wasn't for his help, the project would not have got off the ground.

Since obtaining schematic drawings of both the LB&SCR 5 ton (4 wheel), 10 ton (6 wheel) cranes, along with their match trucks from the NRM, a more accurate drawing was prepared, as my previous 3 drawings were, as mentioned in Part 1, hopelessly wrong. The length of the schematic underframe over headstocks worked out to 18` 0" with a 5` 6" + 5` 6" wheelbase and 3` 1½" diameter wheels. Strangely there are no end views, but gleaning from photos and my original drawings, my estimated width of 7` 0" still looked about right compared to the match truck width. The most crucial area of concern on my original drawings was the position of the pivot of the moving crane body. Thankfully, the schematic drawing clearly shows it's position (49mm in from jib end bufferbeam).

Looking more closely alongside the photo of No.19 (refs 2 and 3), it appears there was an additional added end section 6` 8" deep fitted to the original headstocks underneath the weight box end which extends the overall length to around 18` 8" which is not on the original drawing. The overhang of the moving crane body would have necessitated this extra length as the buffers and drawbar would be set too far inwards. Finally the jib could be drawn on, now knowing precisely where the end pivot position was on the moving crane body.

We are not precisely sure if the crane ever had brakes fitted. Is the wheel on a threaded shaft on the outside face of the sideframes a brake wheel? The bottom of what appears to be two outside clasps almost touch the supporting beam, but are they connected to the brake stems somehow? There are certainly no brakes in between the centre and right hand wheels. But in the darkness could there be brakes on the left and centre wheels? We may never know until a clearer photo turns up.

UNDERFRAME CONSTRUCTION The right hand inner jib end headstock was cut out first (49mm x 12mm) from scrap 1.3mm brass as the photo of No.19 (1 and 2) clearly shows it quite thick on the corner. The other (weight box end) headstock was thinner and normal 18thou brass

used. Having no detail of the drawbar backing plate, I plumped for a rectangular one (8.25mm x 4.25mm) which, when cut out from scrap 10thou brass, the bolt detail was added using my trusty old Cherry Scale rivet press. They were then soldered into position over the drawbar slot. The buffer backing plates were made, again, using the same scrap 1.3mm thick brass x 6.75mm square as these too appear to be very thick. A central 5.7mm diameter hole was drilled out ready for the buffer shanks, and four 0.75mm holes were drilled in each corner ready to accept the mounting bolts. When finished they were soldered directly onto the outside face of the headstock. I noticed the buffer housings and buffer heads of the crane were slightly larger in diameter than the match truck ones. The internet was scoured for suitable ones which looked like these buffers with no success (one did look close but not close enough). In the end, I had no choice other than



Photo 1 - Two views of the completed buffer beams with self-contained buffer housings (1/4th tube) and turned buffer heads. The beams were cut from 18thou and 1.3mm thick brass, with 6.75mm square, 1.3mm thick backing plates. 0.7mm brass rod represents the mounting bolts. The drawbar backing plates measure 8.25mm x 4.25mm and have a 2mm x 1mm slot filed out for the Laurie Griffin drawbar hooks. Buffer heads are home turned and soldered to 7/32nd brass tubing telescoping down to a 1/16th tube which passes through the buffer beam. Also shown is a compression spring and retaining collar for the fully sprung buffer.



A rear view of the thinner 18thou buffer beam, clearly showing the $1/16^{\text{th}}$ inch tubing protruding through. At this early stage the overall length of tubing has not been determined and will be cut shorter to suit later. Four inner holes were drilled out for the buffer mounting bolts, and soldered in from behind with small blobs of solder. The four outer bolts were simply soldered in from the front of the backing plate with the smallest amount of solder. The reason for this is that the sideframes are positioned directly behind where the bolts would be. Note the very small 2mm x 1mm slot for the Laurie Griffin drawbar hook.

to make my own. The outside diameter of the housing worked out to around 5.5mm x 6mm long, so $7/32^{\text{nd}}$ brass tubing (KS Metals ref:KS130) was used, which, when cut to length, were also soldered into position into the pre drilled hole in the backing plates. Finally 0.7mm brass rods were then inserted and soldered into position representing the mounting bolts. The outside diameter of the buffer heads were estimated at 15" (approximately 9mm) which were turned from thick scrap brass. Soldering various sized telescoping brass tubing together from $1/16^{\text{th}}$ (KS Metals ref:KS125) the smallest tube (which passes through the headstock) up to an outside diameter of $3/16^{\text{th}}$ (KS Metals ref:KS129) was soldered centrally onto the back of each buffer head. When finally assembled, a small $1/2''$ x $1/8''$ steel compression spring (Eileens Emporium

ref:SPRC120) will be inserted into the rear of the buffer and held in place by a small collar (Photos 1 and 2).

Having quite a lot of 10thou brass sheets, I thought this thickness would be too flimsy for an underframe. In the end, 18thou brass sheet was chosen (Eileens Emporium ref:SBA018B). During construction of the frame, I thought 18thou was slightly on the thick side, as I was struggling to get heat into the brass in certain areas even using a 50 Watt iron. In hindsight, 15thou would be fine if the project is repeated, though I would still stick with 18thou though for the W-irons where a bit more strength would be required.

As there are a lot of riveted bolt strips virtually everywhere on the real crane, I thought it best to get them etched saving time and accuracy. Punching holes 2.5mm apart on a strip 1mm wide

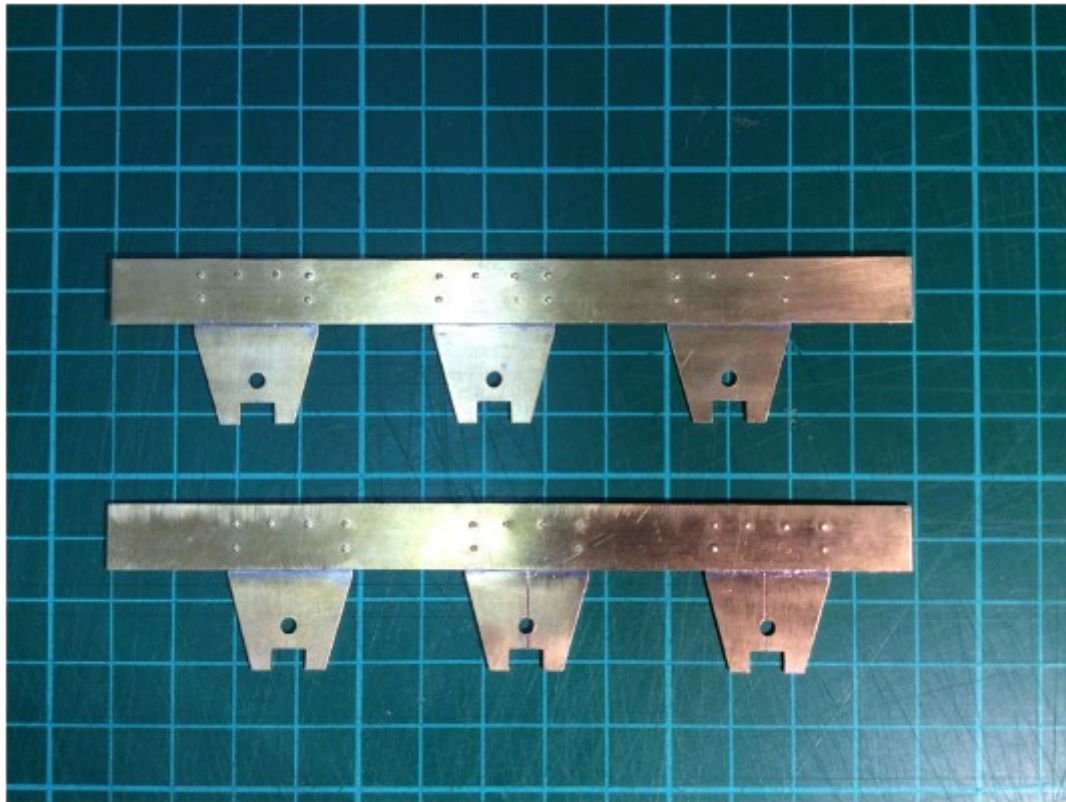

PHOTO 3 - Outer views of the sideframes. Surprisingly for a crane this size, there isn't a lot of bolt detail other than the ones that hold the very large plated W-irons in place (6 for each). A rivet strip 1mm wide with 2.5mm bolt spacings will eventually be cut to length and soldered in position all around the edges. Also note the W-irons are not positioned centrally (i.e. one end is longer than the other) within the frame length and are off centre. The longer overhangs are the weight box ends.

looked impossible. There has always been the problem of the material bending around the rivet deforming the edges. In collaboration with Mike Waldron (EBM Models), he has done the artwork for the moving crane bodies 15mm radiused curved upper sections, and 10" long strips for the remainder of the crane and the jib. The jib has a minimum of 8 long riveted strips alone. Eventually when etched, the over length strips can be cut to suit and soldered into position. Two sideframes were then cut out (129.5mm x 10mm) and all rivet/bolt detail punched in from behind.

Six pieces of 18thou were soldered together for the large W-irons. A photocopy of the iron was printed off and glued on. A 2.5mm diameter hole for the Slaters top hat bearing was done first before any cutting was started. Once completed, they were then unsoldered and cleaned up. The same procedure applied with the keeper plates. Next was to solder the W-irons behind the solebars making sure they were in-line with the rivet/bolt detail on the front (Photo 3 and 4).

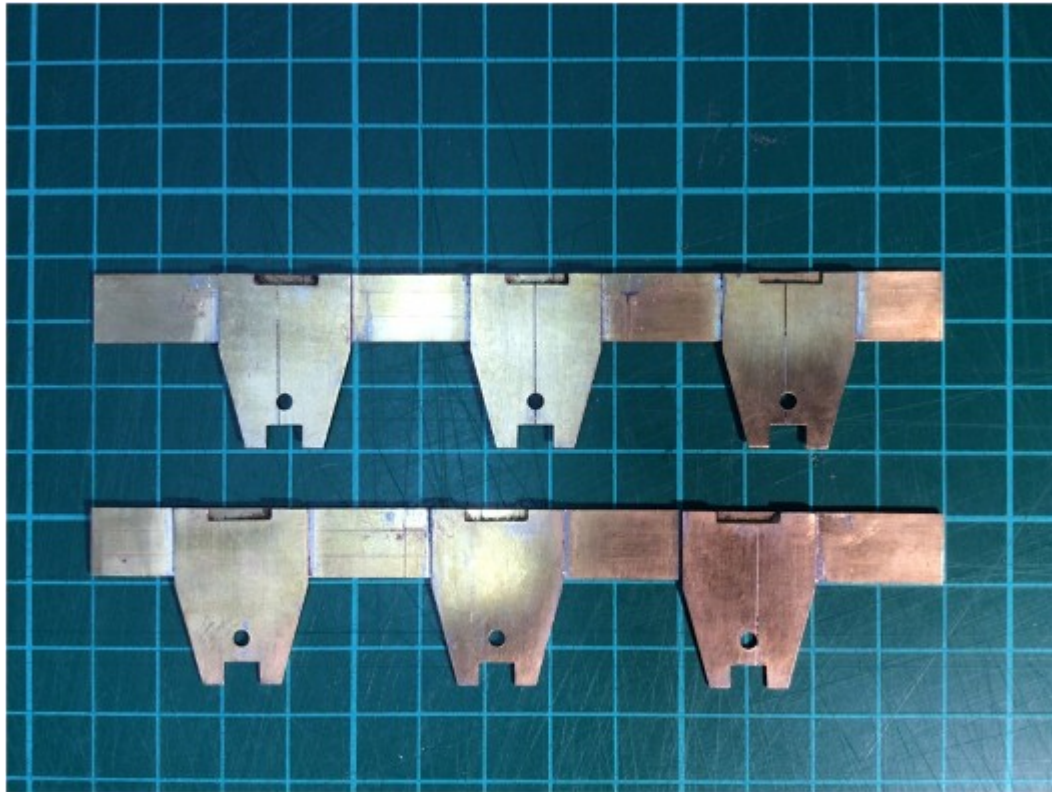

PHOTO 4

A rear view of the side frames showing the large W-irons soldered into position. The irons were made by soldering six, 18thou scrap pieces of brass together. A photocopy of the W-iron was then glued on, then cut out `as one` with a piercing saw. The small cut out slots along the top of each iron are purely for an extra bit of solder for strength. Note. Ignore the randomly etched lines on some of the irons as a piece of scrap locomotive etch was used for them. Eventually these line will be completely hidden.

An 18thou rectangular top plate (129.5mm x 49mm) was cut out and a hole drilled out for the central column and bearing base ring which was kindly turned by Francis (Photos 5 and 6). At long last, the completed headstocks can now be soldered onto the ends of the top plate.

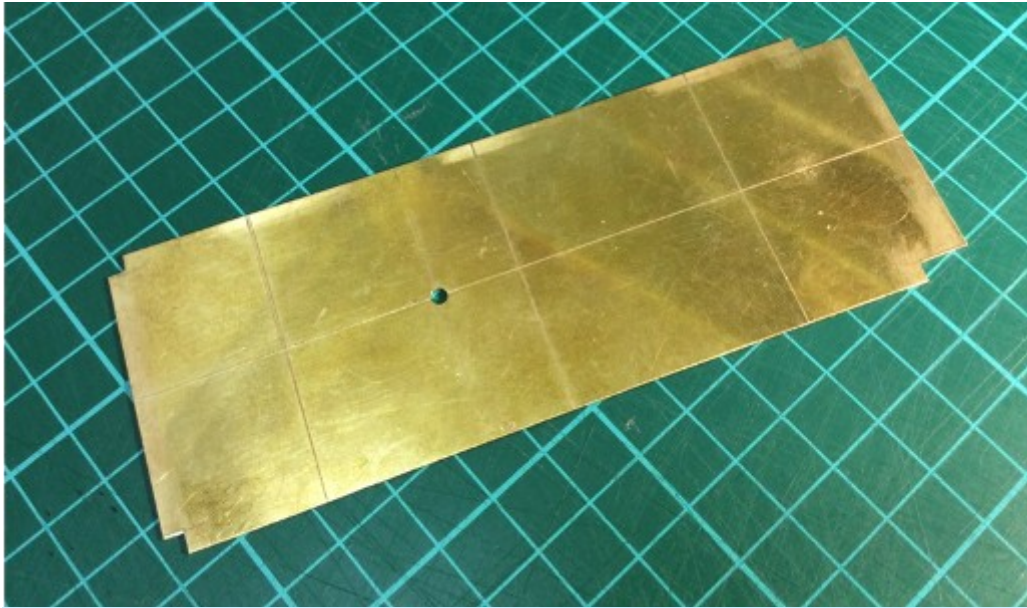

PHOTO 5 - An underside view of the rectangular top plate which was cut from a piece of 18thou brass to 129.5mm x 49mm. The scribed lines show a long central line and three axle position lines (5` 6" x 5` 6") as a guide. The drilled out hole is for the column and bearing base ring for the moving crane body. The small square cut outs (3mm x 2mm) are for the thinner `jib end` headstock, whilst the longer rectangular cut outs (9mm x 2mm) are for the longer weight box end headstock.



PHOTO 6 - A posed photo showing the column and bearing base ring (which was kindly turned for me by Francis of 3D-COMPANIONS) positioned on top of the rectangular top base plate. The purpose of the column is to support the moving crane body (Part 3). The ring will eventually hold 39, 2mm diameter stainless steel balls for the body to rotate freely on, eventually encapsulating them. On the extreme top of the column (where the screw is), a 5mm diameter parallel section 3mm deep has been turned. This is for the mid-support section that is positioned in between the two moving crane sideframes.

Using Slaters 3` 1", 8 spoke wheels (ref:7121), the distance between the back of the W-irons needs to be 42mm. This obviously sets the outside face of the sideframe inwards slightly from behind the headstocks at 3mm in from each corner (Figure 1). Running along the bottom of the sideframes is a flat edge. To represent this, a length of 3mm x 4mm unequal "L"

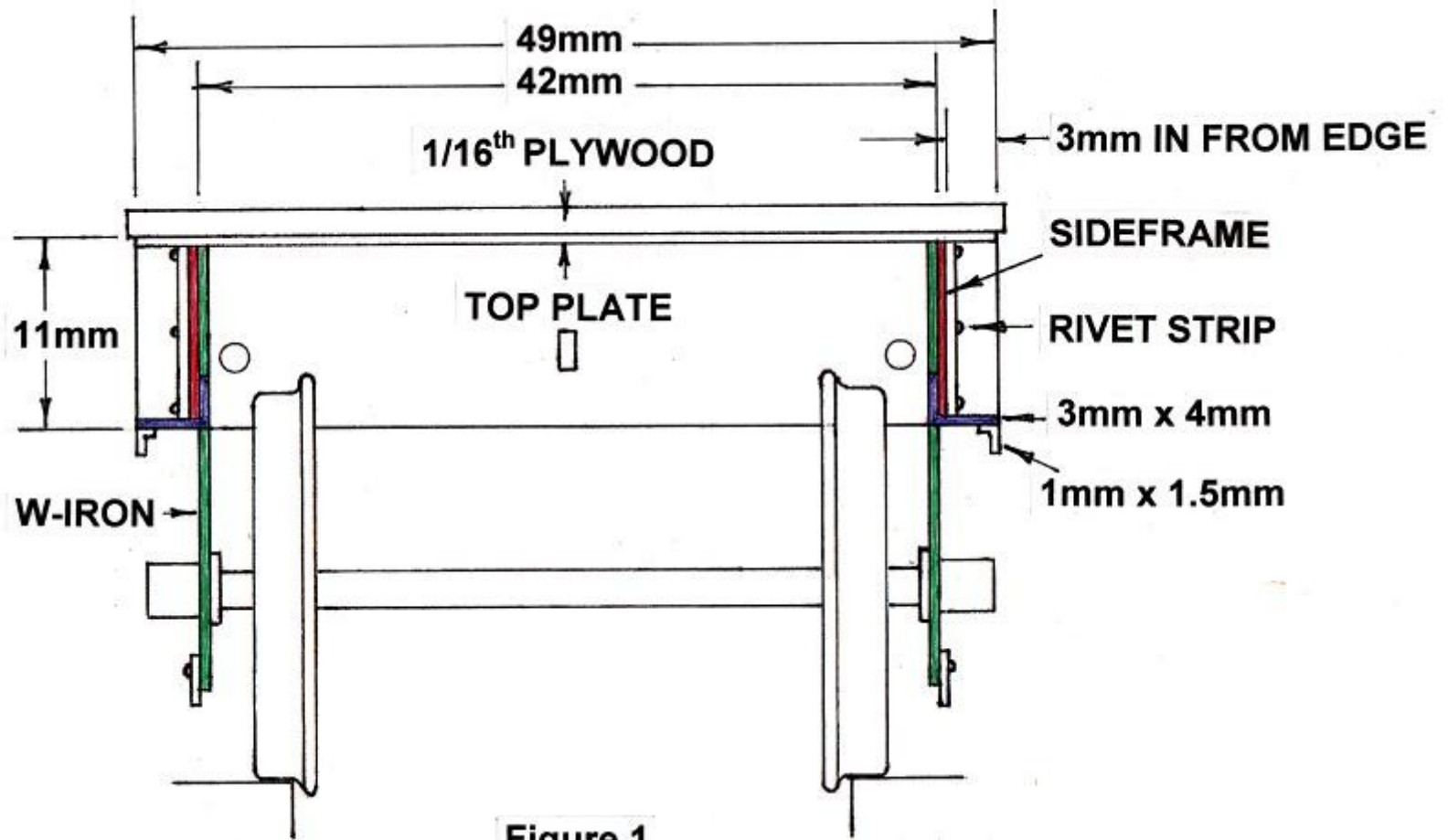

Figure 1

angled section is required (Eileens Emporium ref:L04030C). Before soldering in place, three 20mm wide slots need to be cut out (on the 3mm side) to clear the backs of the W-irons. It was very tricky getting every slot to line-up perfectly with the W-irons. Only now can the strip be soldered onto the rear (inner side) of the sideframes. The outside edge (should) line up perfectly with the bottom corner of the headstocks. Finally the sideframes can be soldered to the bottom of the rectangular top plate encapsulating the outer (weight box) axle. A rocking unit was designed and fitted to the inner (jib end) axle. The centre axle was going to be lightly sprung.



A cardboard mock-up of the crane with jib was made and placed over the central column and base ring. It also gave me any idea of what it would eventually look like (Photo 7). When completed, a trial run was made through the cross-over catch point section of pointwork on the garden railway. The jib slid over the top flat match truck frame perfectly (just like the real thing would have done), but I noticed the fixed “outer weight box end” axle derailed. Even after a number of slight modifications, it derailed again. The final modification was to temporarily un-compensate the rocking axle thus making it into a rigid axle (packing the

PHOTO 7 - A very crude cardboard mock-up of the moving crane body with jib just to show what the finished model will eventually look like. I was concerned about the overall length of the jib being too long as it overhangs the end of the match truck by a few inches on the photo of No.19. I needn't have worried as my current drawing was spot on. With the moving crane body fixed in the forward facing position, it was pushed and pulled through a crossover. At that time, the underframe had a rocking unit on the jib axle, but due to constant derailments, it was taken off. After modification to a ridged underframe there were no more derailments. On the plus side, the jib slid from side to side along the top of the match trucks supporting beam prototypically with a few millimetres to spare in from each end. When the photo was taken, the underframe only had headstocks made from Plastikard, no supporting beams, or keeper plates.

underside of the unit). The next trial run there was no derailment at all in either direction. So reluctantly the underframe is now non-compensated. The rocking unit was removed and the frame taken apart. It was reassembled encapsulating the two outer axles. Another test again revealed no derailments. The centre axle at the moment just floats up and down within a slot of two elongated “L” shaped brackets, but will eventually be lightly sprung.

Pieces of scrap brass (11mm x 9mm) were cut out to represent the thickish packing section behind the weight box end headstock and soldered into position. A 3mm square section x 10mm long brass tubing was used for the packing section on the jib end.

The two large stabilising “I” beams had to be scratch built as no commercial ones are available in this unusual size. 4 pieces each of 6mm (horizontal) and 8.5mm (vertical) wide were cut out from 10thou scrap brass. At this stage, I am not precisely sure how long they need to be but I chose a length of 6cm (8` 6”). To solder them up square, a former was made (2.5mm x 8.5mm plywood) and the individual items held together around it. After several attempts they were, at last, finally soldered up square (Photo 8).

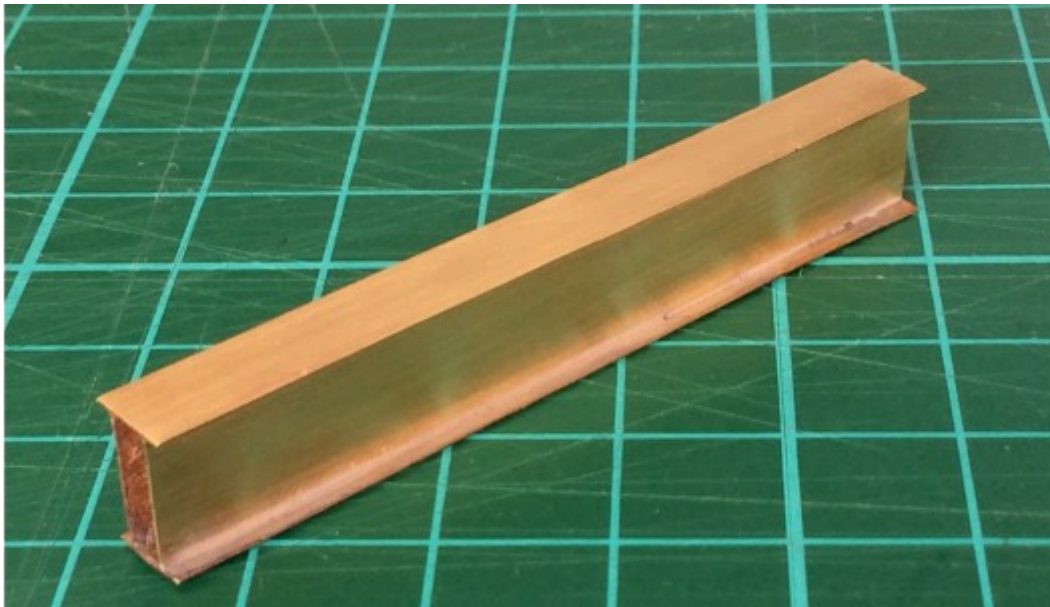

PHOTO 8

A completed support beam. It is soldered together from four pieces of scrap 10thou brass with the aid of a wooden former 2.5mm thick by 8.5mm wide to keep the sides parallel and vertical for soldering. The top and bottom strips are 6mm wide, and the sides 8.5mm deep. The overall length at the moment is 6cm (scale 8` 6”). This may be cut shorter as I think they might be slightly too long.

The internal supports from which the beams slide in gave me a lot of headaches to design. In the end, a strip of 7mm wide C&L Doublesided Copperclad sleeper strip (C&L ref:7ZC101B) was used and filed down to 6.5mm and cut to 41mm long. As there isn't currently a 5mm x 1.5mm unequal brass section available for the beams to slide in, 0.5mm has to be filed off the 2mm edge of a 2mm x 5mm unequal brass section (Eileens Emporium ref:L05020D). Remember, it is trial and error as only a very small gap (10-15thou) was required for the beams to slide in. When completed, they were simply soldered onto the rear of the solebars (Photo 9).

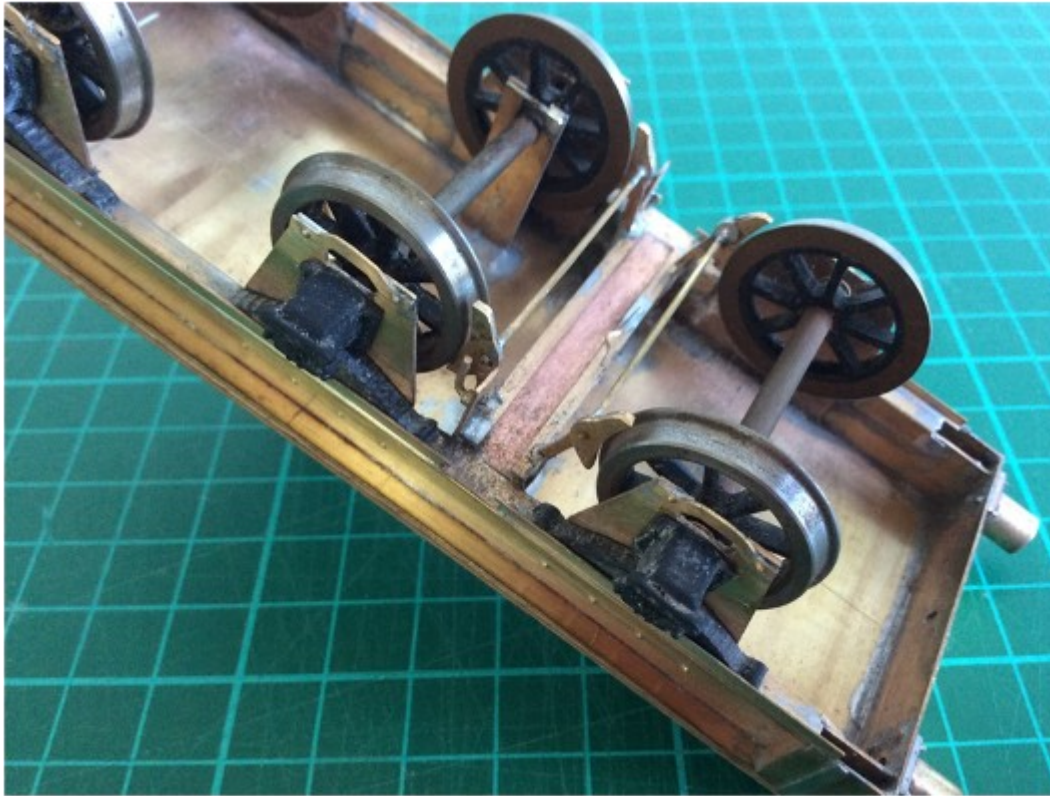

PHOTO 9 - Close up showing the brake blocks and stems. These too were soldered up and cut out `as one` then unsoldered and cleaned. Four shoes were then soldered onto the front face thickening them up slightly. For extra strength, a piece of 0.7mm diameter rod was then soldered through the blocks themselves. As mentioned in the text, I am not sure if brakes were ever fitted or how they were operated. If they did not have brakes, they can simply be removed. The mounting supports on the ends of the leafsprings are hidden by the small angled strip (which can just be seen) running along the bottom edge of the sideframe. Note the doublesided copperclad sleeper strip, angled sections, and narrow slots for the support beam to slide in.

The supporting ends of the leafsprings on No.19 appear at first glance to be missing. Very close examination reveals a narrow strip that is secured underneath the flat bottom edge of the sideframes which is hiding them. A piece of 1mm x 1.5mm unequal brass section (Eileens Emporium ref:L01510D) was cut up into three bits, filed, and soldered into position (the 1mm edge is soldered to the underside of the side flats). Just for the photos, one side only has had the leafsprings and oil filed axleboxes temporarily fitted which were 3D printed by Francis (Photo 10). The other side of the underframe has been left undetailed (Photo 11). Note too in both photos the thin wooden top decking section cut from 1/16`` plywood measuring 134mm x 50mm.

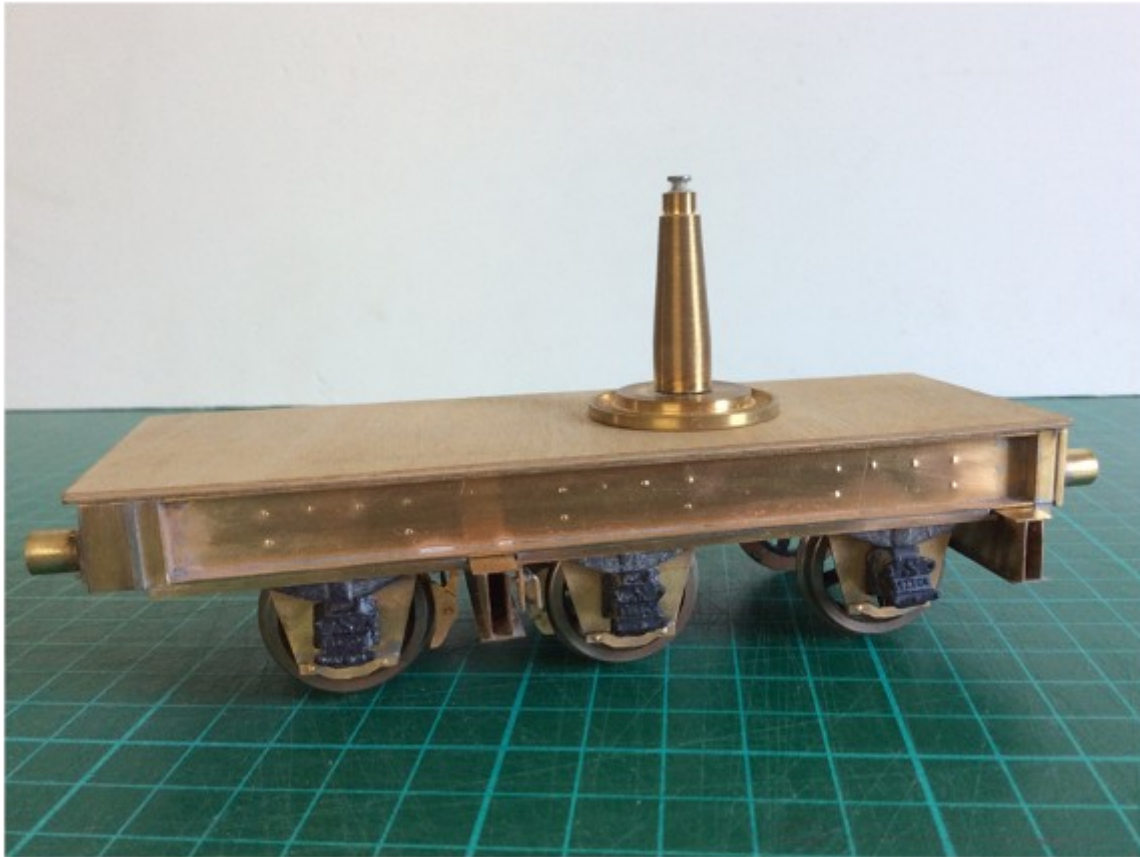

PHOTO 10

Side on view showing the nearly completed underframe, barring the rivet/bolt strips, brake wheel (?) and clasps. Temporarily fitted are the oil filed axleboxes and leafsprings. As mentioned in the text, the extreme ends of the leafsprings are hidden by the small angled strip running along the bottom edge of the sideframe. Also shown are the long keeper plates which have been soldered onto the bottom of the stumpy W-iron legs. They too were cut out in exactly the same way as the W-irons. The right hand (jib end) headstock is noticeably thicker as shown on the photo of No.19 which I've replicated also.



PHOTO 11 - This near side view is lacking the oil axleboxes and leafsprings but gives a good impression of how large the W-irons actually are. As the centre axle floats up and down (± 2 mm), the top hat bearing which is soldered onto the back of the iron is purely cosmetic and corresponds with the hole on the rear of the axlebox. The wooden decking has yet to be scribed with planking and is plain at the moment. The extra work taken adding the 0.7mm brass rods in the drawbar, and buffer backing plates were well worth the effort as can be seen. Note the excellent Laurie Griffin drawbar hook.

Photo 12 shows an overall underside view. A lot of work has gone into getting this far, especially designing and making the jib end internal support for the supporting beam (top of photo) to clear both the back of the drawbar hook and spring, and the front edge of W-irons. It looks relatively easy looking at the photo, but was far from simple.

Finally the brakes (if fitted in reality as mentioned above). They were also scratch built with long stems which were bent up and soldered to the underside of the top base plate. For extra support, they were soldered to the outside face of the internal beams supports (Photo 9 again and 14).



PHOTO 12 -

Underside view with the supporting beams in place. The “L” brackets for the floating axle can just be seen with a thin diameter brass rod `keeper plate` holding the axle in place. There is just enough movement to negotiate a standard 6` radius Peco point. A bonus from using the Laurie Griffin drawbar hooks are their length. With the straight portion being 17mm long, it gave me an extra bit of space underneath the jib end to fit the internal beam support. It had to be slightly modified with a small slot for the spring clearance. Note, the spring can just be seen protruding out from underneath it. The weight box end drawbar hook will be cut much shorter.

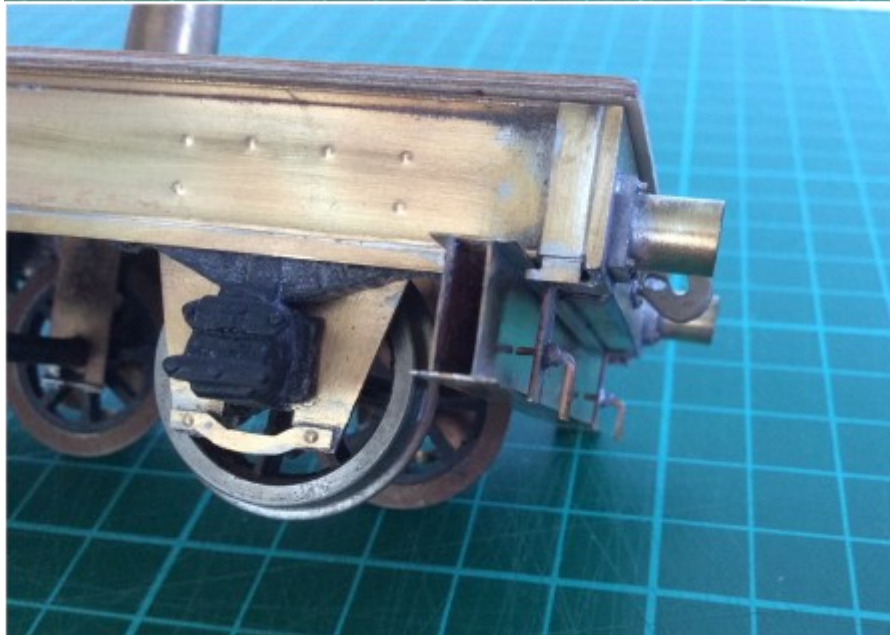

PHOTO 13 - This view shows the supporting beams in the travelling position. To secure the beams from moving within the slot, two threaded handles on each beam were used to lock the beam in position. They are just visible on the photo of No.19. I bent up a piece of 3mm wide scrap brass into an unequal “L” 9mm x 3mm and soldered them directly onto the bottom of the headstock (jib end shown). A piece of 0.7mm brass rod was soldered into it to form the threaded handle. Just visible is one of the brackets for the centre axle to float up and down in.



Photo 14 - A close up showing the brakes if they were fitted. Their design has been copied from various brake block shapes and sizes of goods wagons etc. They were cut from scrap brass with a brake block overlay. Looking quite bare at the moment, the sideframe will eventually have the 1mm wide rivet strip soldered on around the extreme inner edges. Only then can the brake wheel (?) be made with the drop down clasps. Note also the very small opening (6.25mm x 0.75mm) for the "I" beam to slide in which is very prominent feature on the real No.19.

At the time of writing (end of May), I have just taken delivery of the etched rivet strips for the crane from Mike.

Photo 15 shows a small area of the etch. Remember they are 1mm wide with 2.5mm rivet spacings. The rivet spacings was estimated from the jib of No.19 which, when counted, matched a spacing of approximately 2.5mm (give or take +/- 0.1mm). The rivet spacing on the underframe`s sideframe were very slightly narrower, but I am happy with an overall impression of equally spaced rivets.

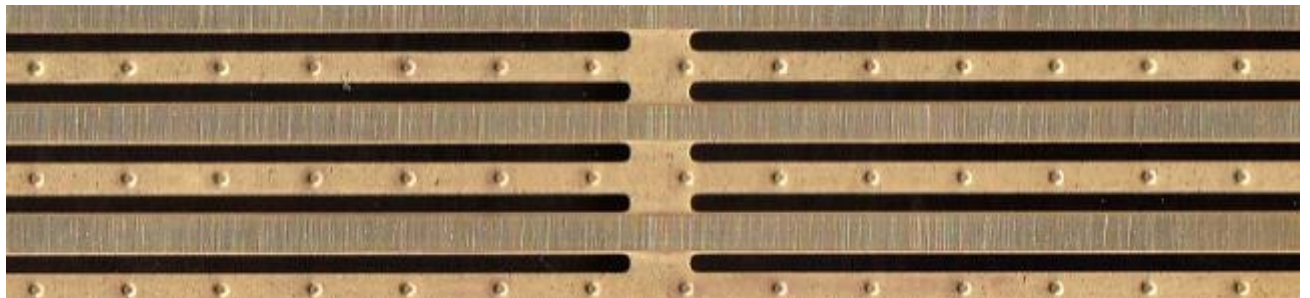

References

Plate 123, Page 73, AN ILLUSTRATED HISTORY of SOUTHERN WAGONS Vol 2.

Plate 121, Page 72, AN ILLUSTRATED HISTORY of SOUTHERN WAGONS Vol.2, .

Page 29, LB&SCR Modellers' Digest No.1, .

This concludes the building of the crane`s underframe to date. As mentioned, Part 3 will concentrate on the moving crane body, but a brief update on the finished underframe with the etched rivet/bolt strips, brake wheels, clasps and footboards etc, will also be included.

All photographs copyright Colin Paul

[Index](#)

Shorter Trains

By Nick Holliday

A recent article in Model Rail magazine focussed attention on short trains, up to two coaches long, as a way to solve the modellers' perennial problem of lack of space for a layout. Whilst this covered the period of British Railways, when the railways were largely in decline, and passenger traffic on many lines had dwindled to almost nothing, those of us who model the LBSC in its heyday have already discovered that a small tank engine with three or four four-wheeled coaches makes a more than satisfying train, whilst taking up much less space than even a two coach EMU, and being infinitely more colourful.

When the first railways were opened, the companies had little idea how their traffic would develop. Some had grand aspirations to carry thousands of passengers, whilst others based their hopes on carrying goods, and built their stations accordingly, often resulting in over-optimistic provisions, or sadly inadequate facilities. At least the latter could usually be resolved by expansion or rebuilding to accommodate the actual trade. During this period of discovery and development, which included the public over-coming their fear of railway travel, for every 35 coach excursion train that might hit the headlines, on the many branchlines, three or four small four-wheeled coaches would be more than sufficient to meet the demands.

The Brighton system was almost fully developed by the 1880's with many main line services comprised lengthy trains of mixed six and four wheeled coaches, with a liberal sprinkling of NPC's. Some commuter trains consisted of 14 close coupled four wheel coaches. However, for the next twenty five years many branch lines were served by only slightly more modern stock.

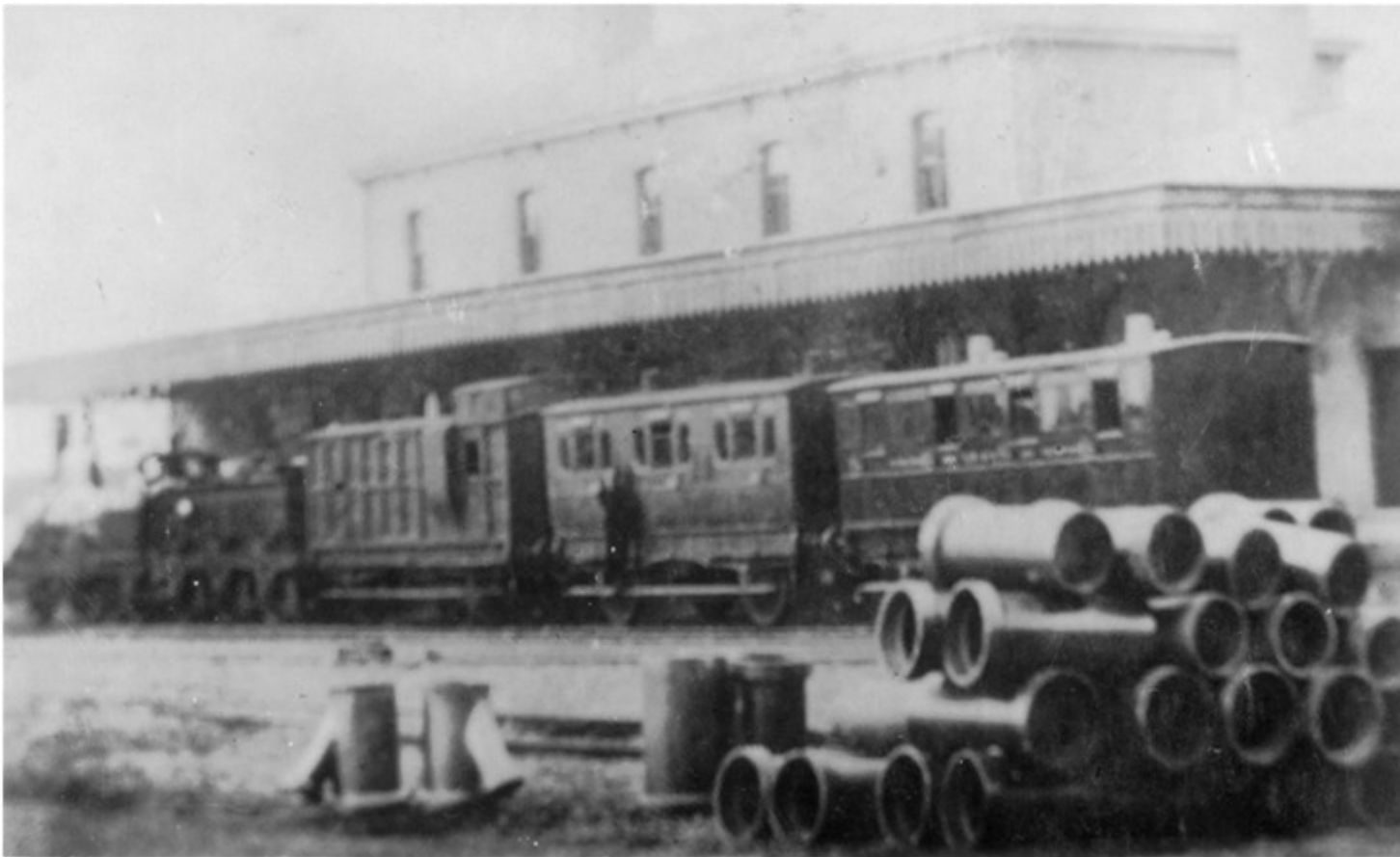

Left

Claimed to be the first train to Seaford.

Below

Jenny Lind with three Craven carriages - all from the 5 & 9 range of kits





Left

Terrier with three coach
train at Selsdon Road.

Below

Dapol Terrier with three
K's 4 wheeled coaches
(total length 17" in 4mm
scale)



By the turn of the century longer bogie stock was becoming the norm, with many arranged in sets of three or four coaches semi-permanently coupled, and often running in combinations of two or three sets, with additional full brakes at each end, rather beyond the current scope. However, by 1905 traffic receipts on some lines were falling for various reasons, and costs were rising too, which caused the Brighton to investigate alternative ways of providing passenger accommodation economically, and comparative trials of steam and petrol railmotors, and purpose-built trailer coaches pull-pushed by old tank locos. These trials resulted in the adoption of the pull-push idea for many services, which expanded up till the time of grouping in 1923.



Terrier with balloon autocoach at Brighton.

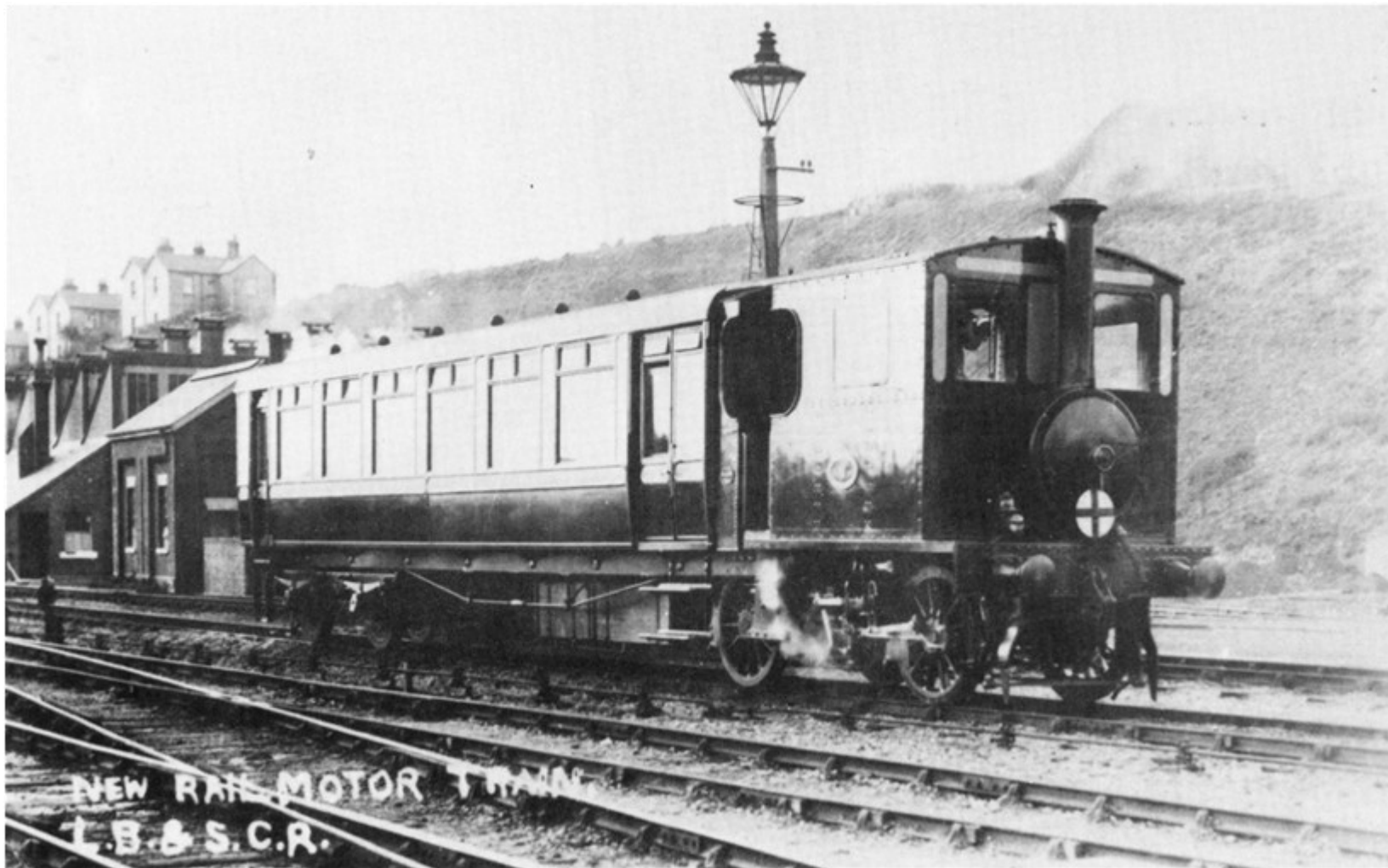

LBSCR Steam
railmotor at West
Marina station

The idea of this series is to provide additional photographic evidence to inspire and support the notion that such short trains did actually run on a regular basis, and provide some information as to which kits and RTR stock are available to allow such trains to be modelled.

Lewes Station 1857 to 1889 — Virtual Models

By David Rigler

My article in Edition 2 concentrated on the 3D models I had created of the main buildings and structures of the second development of Lewes Station. Since that article some interest has been shown in the overall scene I was able to create by bringing all these models together. This article focuses on showing more views, particularly from angles not available in photographs. This is most evident in the first four views, which are from an aerial perspective. The closest photograph to this is by Reeves from the top of Lewes castle!

Note: Not all models of buildings canopies and walls have been completed. Trackwork and ground topography are not modelled.

by kind permission Sussex Archaeological Society

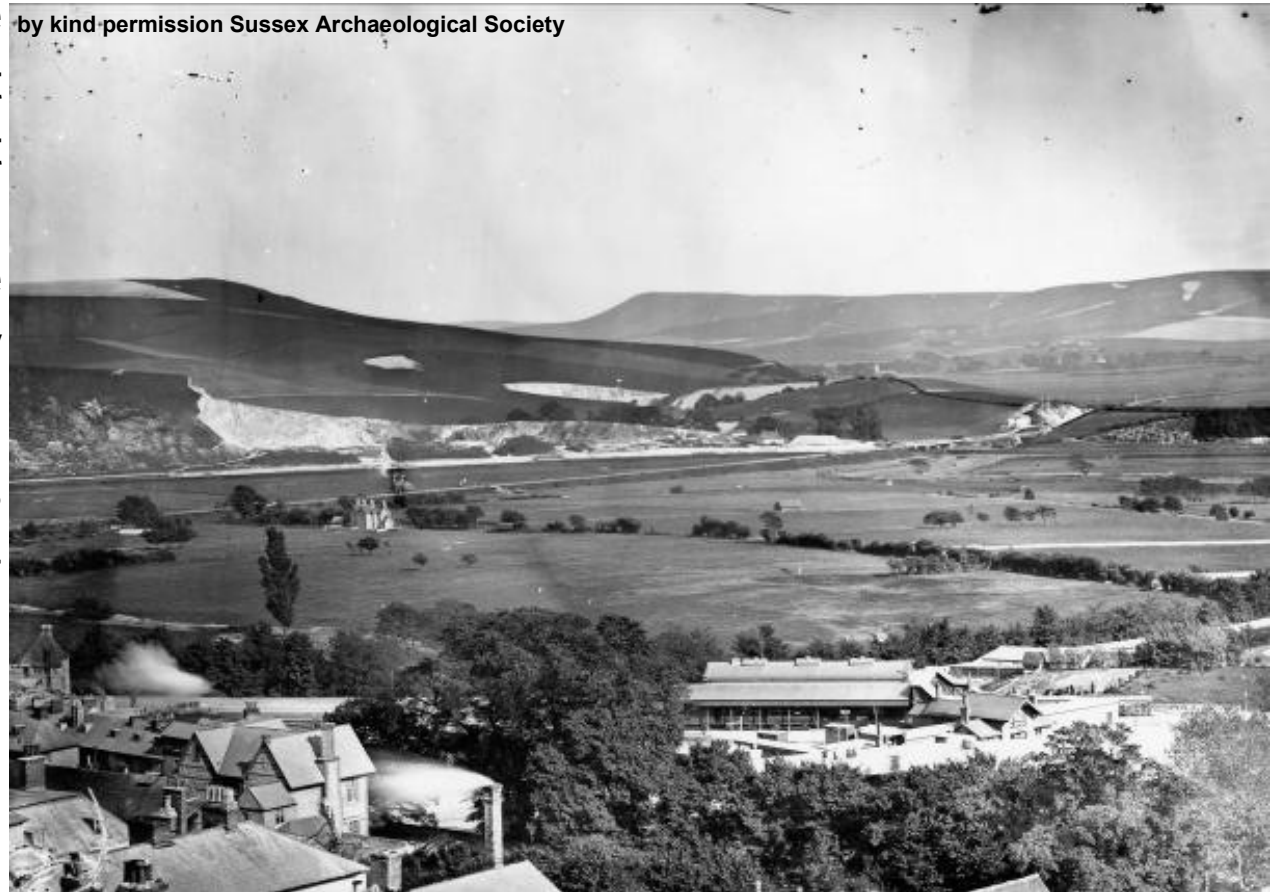

The individual view directions are indicated by the arrows and letters superimposed on the map.

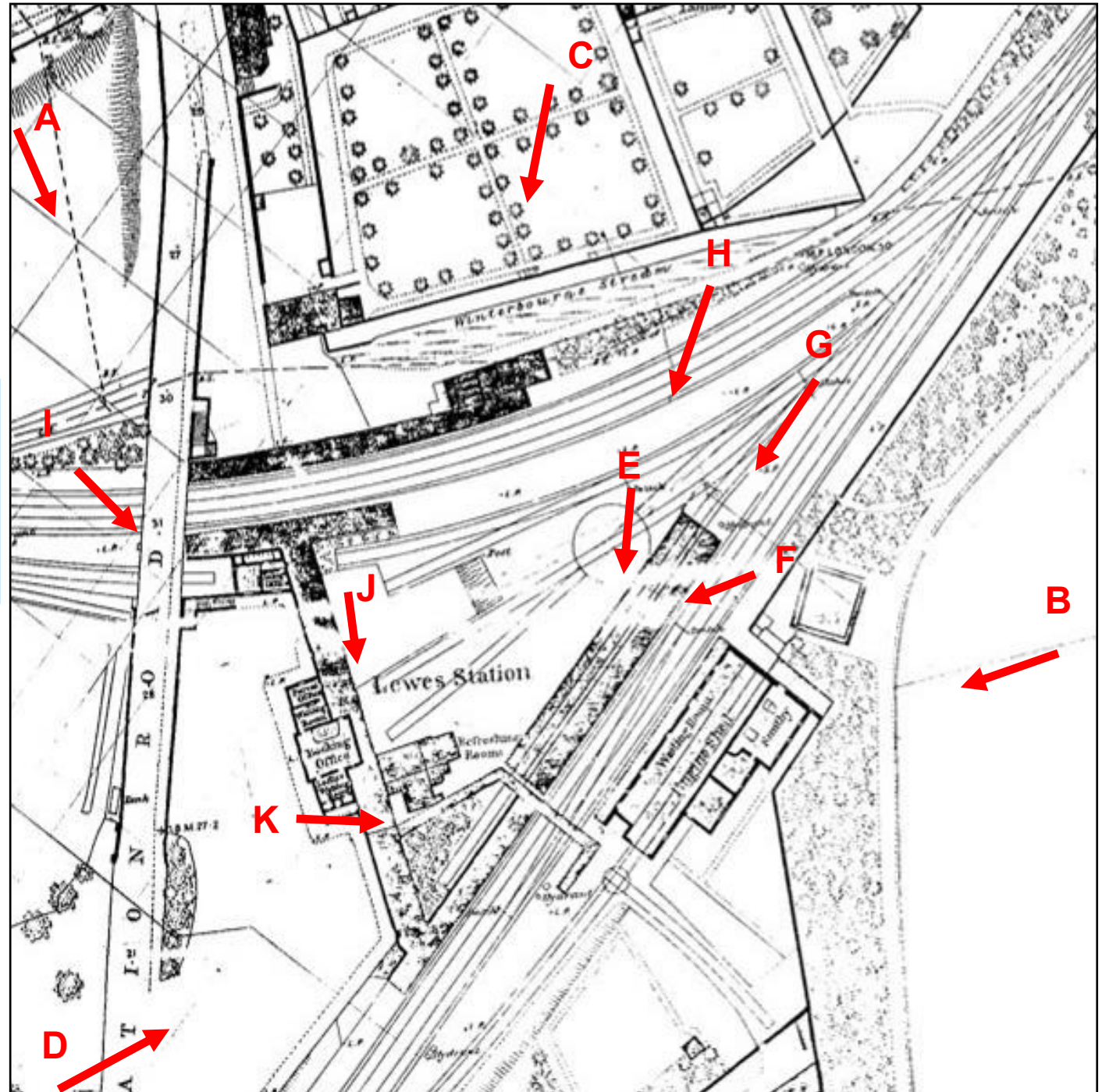

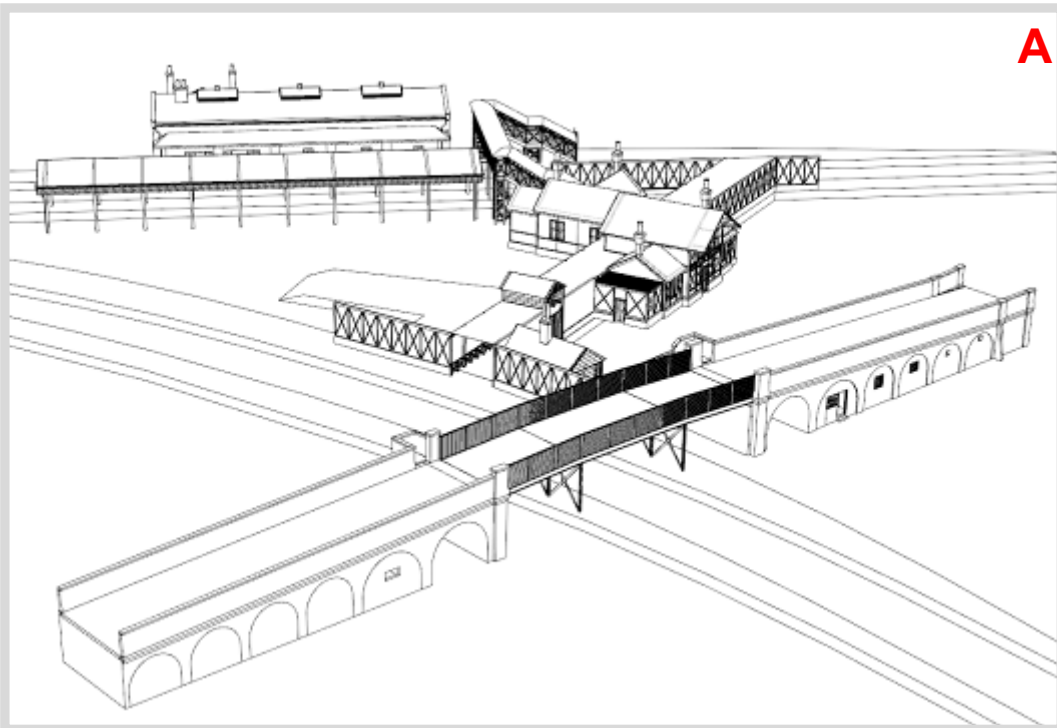
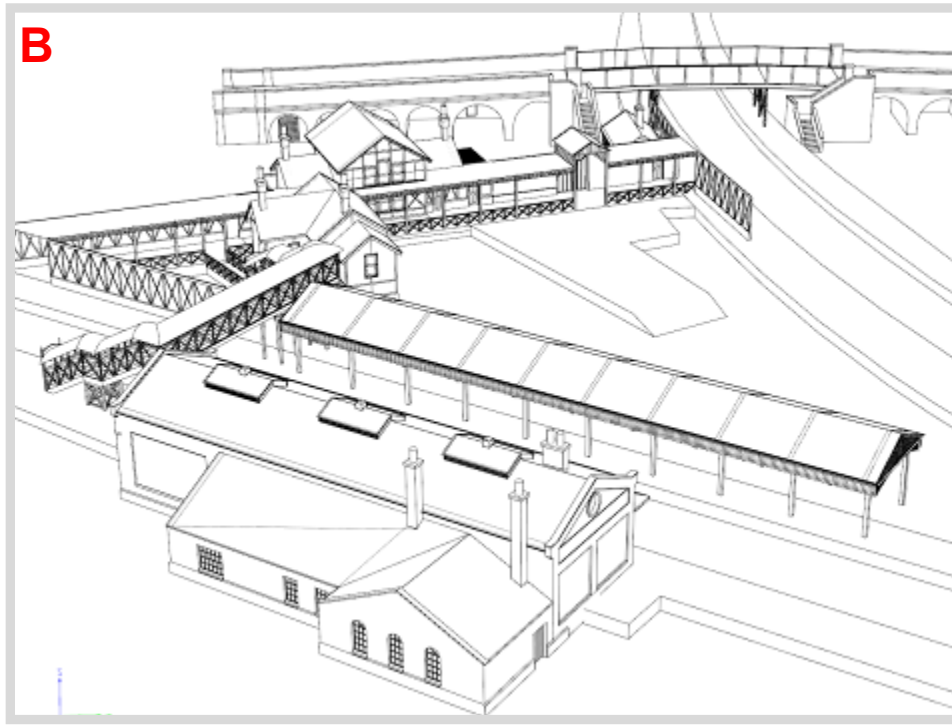
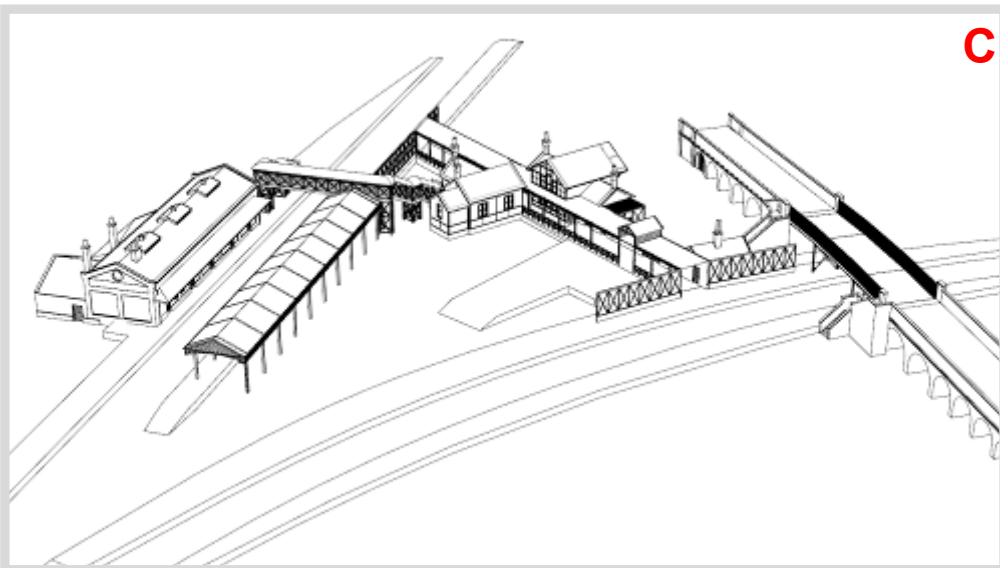
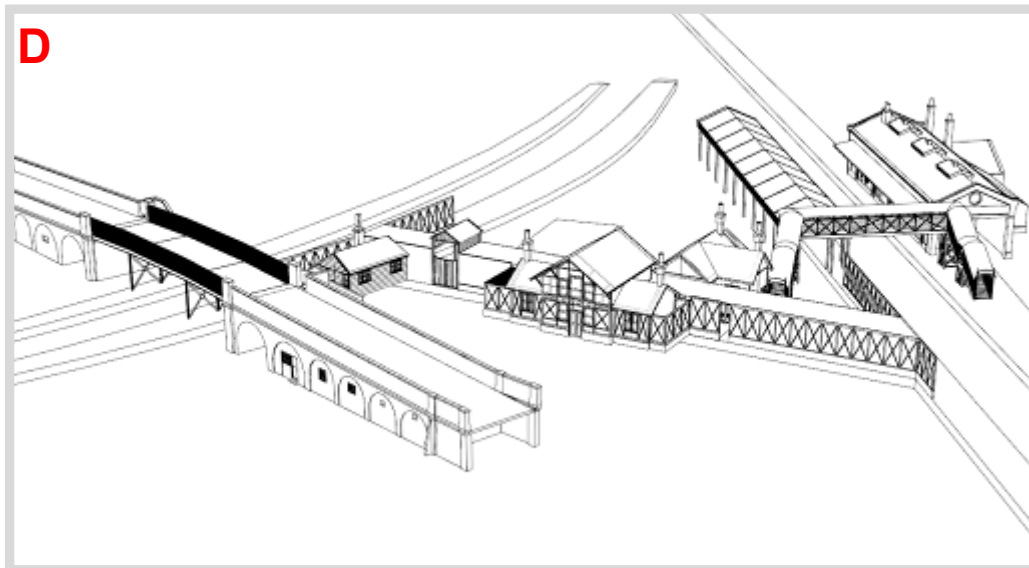
A**B****C****D**

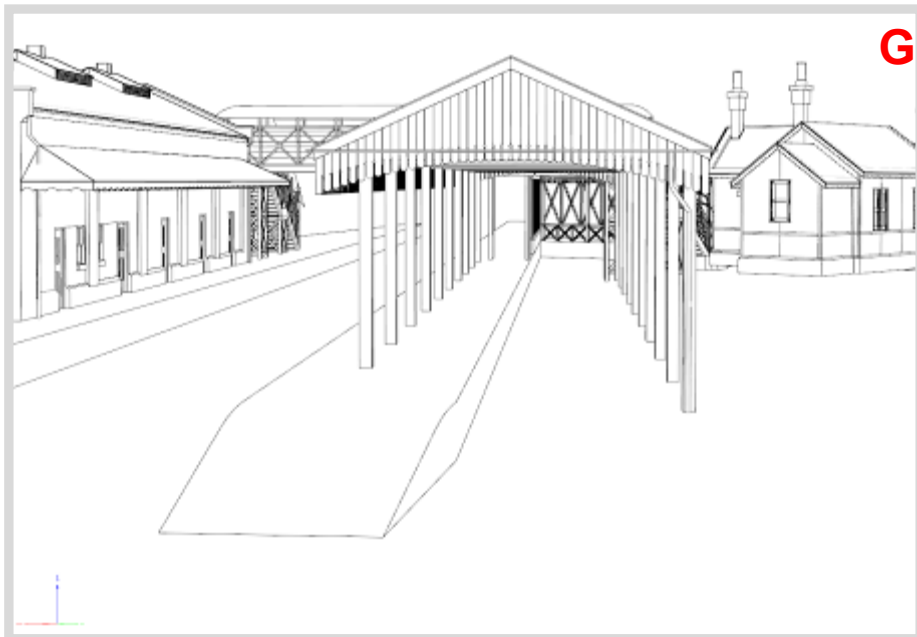
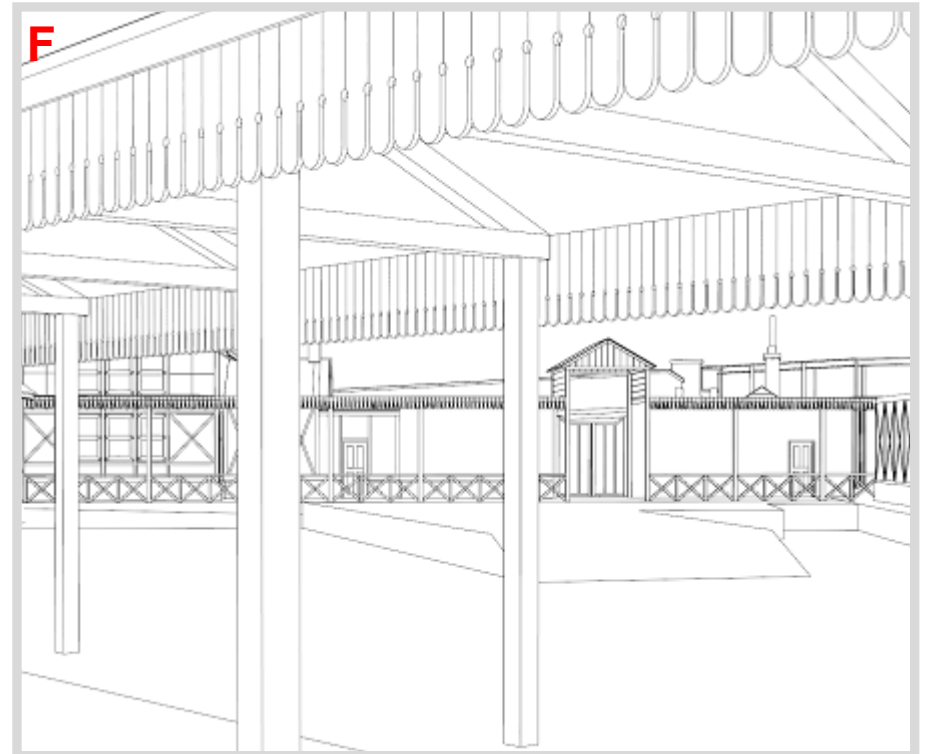



I

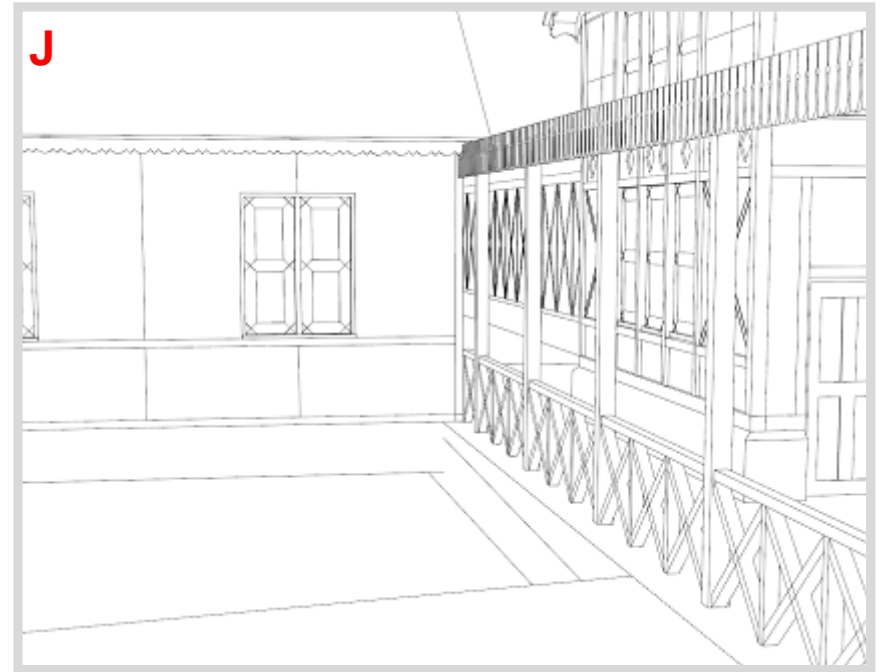

J

For those technically interested in how the “Overall Scene” model is created.

I photographed the large scale map of the station area and imported it on its own layer into the Overall Scene drawing file. I then scaled it to full size (I model the buildings at full size).

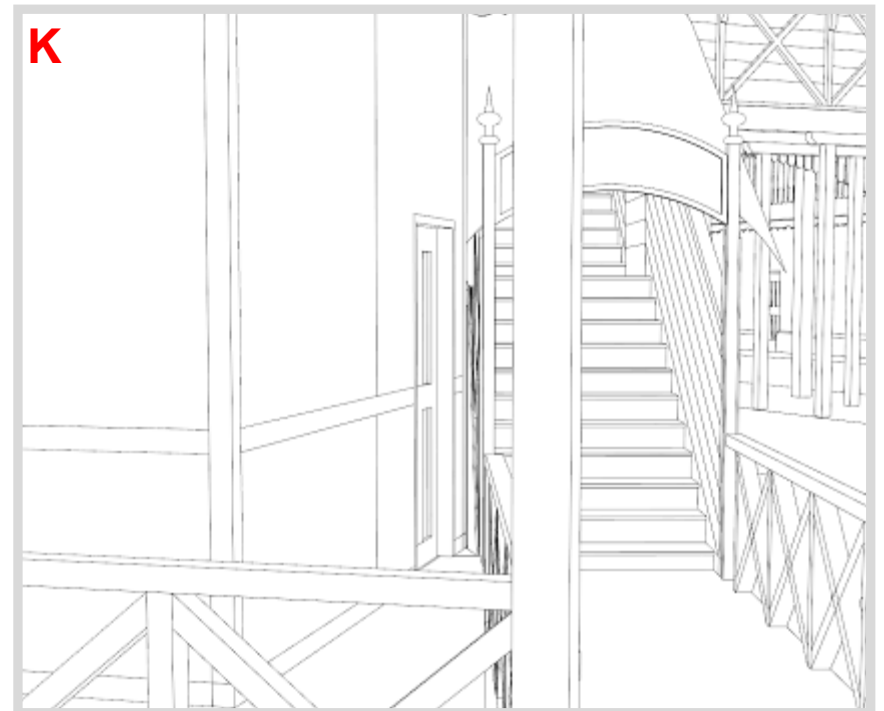

K

A copy is made of each individual building 3D model, flattened to one layer. A template of the footprint of the building is made and this is imported / copied into the Overall Scene file, first to enable accurate positioning over the map layer. Once this is done, the building model is imported and oriented and snapped to its template. With the building models in place, the platforms, interconnecting walls and canopies are modelled to improve the scene.

The CAD package I use is TurboCad Professional



Enlarged section of the previous photo, showing station area.

By kind permission Sussex Archaeological Society

Photos by kind permission Sussex Archaeological Society

Visualisations copyright David Rigler

[Index](#)

A Mystery Photo

By Mike Cruttenden

Can anyone recognise the photo on the next page please?

The picture shows a Stroudley D class 0-4-2, Albion, with a couple of wagons and with an Adams radial tank in the background, running on a ground level garden railway. There is not much to date the picture, but there is a 1930s feel about it. The blistering of the paintwork on the boiler suggests a live steam loco, which may mean that it is larger than O gauge - possibly Gauge 1.

On the back are the words "Albion presented to BTC", which, if this stands for British Transport Commission, implies that the photo is in the National Collection at York.

The card comes from the late Ian Dawson's collection, which is now in the hands of Arch Overbury.

Can anyone provide any additional information please?

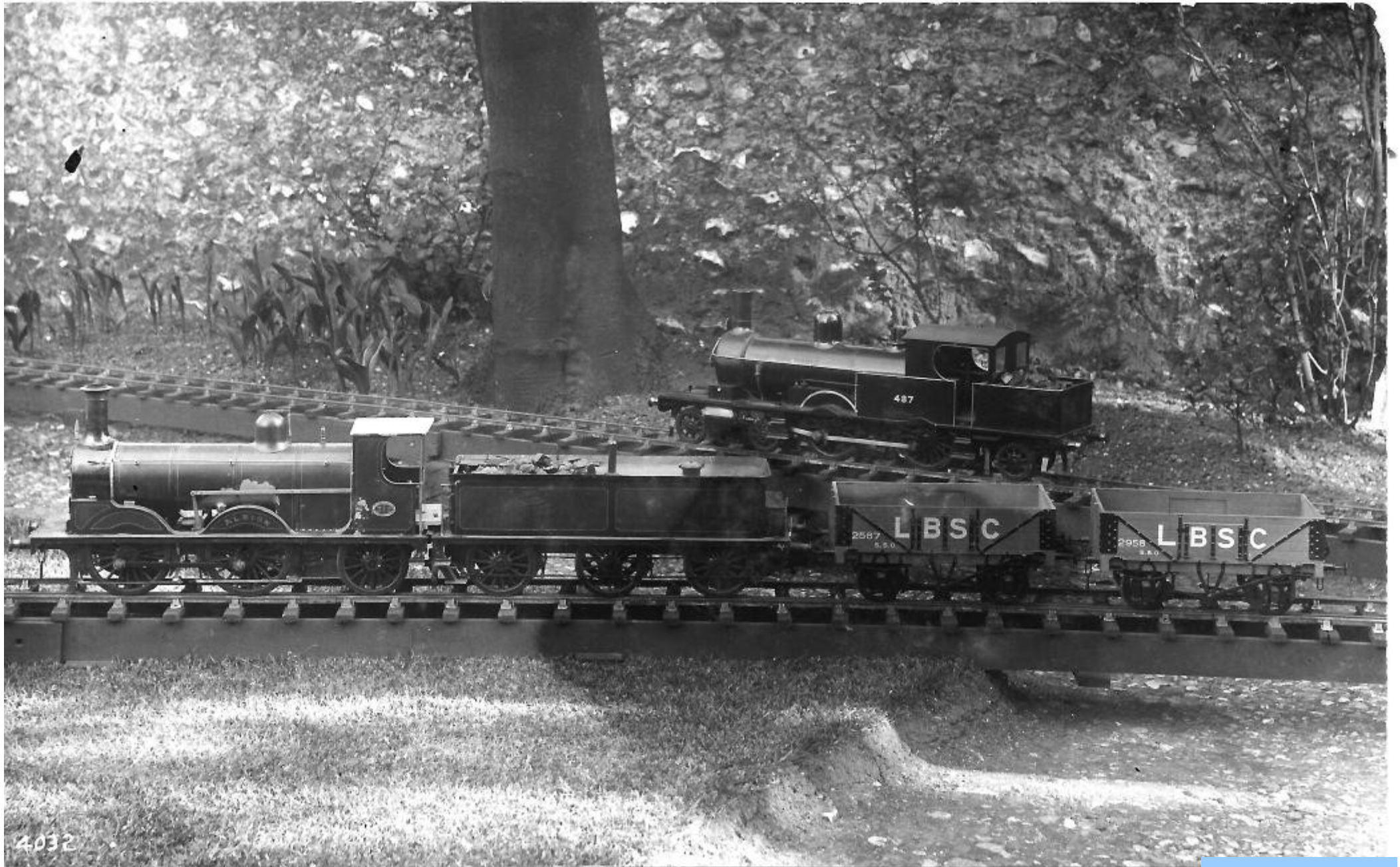

A low cost rolling road - on test

By Ian White

For many years I have tested models either on a length of straight track or on the layout. A few months ago I was asked what rolling road I used and that set me wondering if I needed one, given that they tend to be rather expensive. However I had noticed that at exhibitions in and around my area a small trader called Direct Train Spares (Burnley) had simple rolling road units on display. So at the recent New Mills Show I purchased a set of four of their 00 cradle units for an exhibition price of £33. They had sold out of 00 units by the time I asked but were happy to send them on to me with no postal charge. They arrived a few days later.

<http://www.directtrainspares-burnley.co.uk/>

Each cradle comprises four 10mm roller bearings set in pairs 12mm apart in carefully machined sections of 24mm long aluminium angle, so you can't put the cradles less than 24mm apart and the 6ft wheel separation of a Terrier is at the limit of the product. Additional cradles can be purchased and the cradle is dedicated to your chosen gauge which keeps the price down.

Although the instructions were to loosen the screws on one side with the supplied Allen key and then nip them up to the track, I found the units were set exactly to snap cleanly into a short scrap length of finescale track; it worked equally well with SMP Scaleway or C&L track. I placed my part-built E.B. Models kit of 18/21 on three cradles (photo 1). At that stage the model had acceptable running in reverse but not forwards. The obvious advantage to seeing it on the rolling road is that

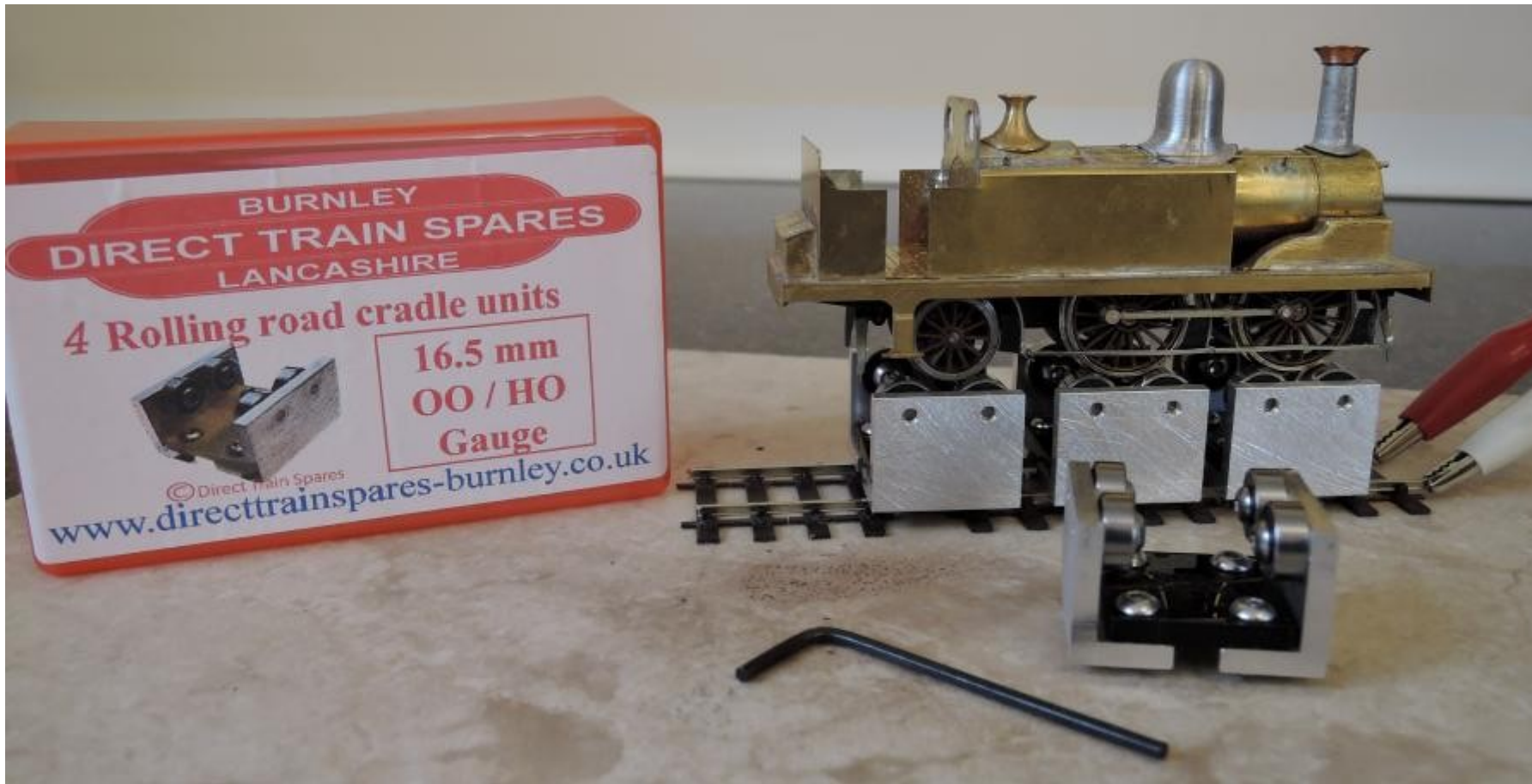

the loco itself stays still while you watch to see where the tight spots are. I knew that the coupling rods had been tested before the motor was fitted so I ruled them out. I found that I needed to move the

main drive gear slightly further from the centre of the axle to get free running and ease the brake pulls rods away from live wheels to prevent an intermittent short. Problems solved!

Fitting the model carefully to the cradle is important otherwise the rolling road itself causes a running problem. Small wheels will sit lower in the rollers than large wheels so I found that the cradle which takes the trailing wheels had to be moved slightly until the footplate was level with the table under the track. That can be seen best in photo 2 which shows my part-built Richmond class (*Hartington*) sat on the rollers. I also tested the units with two Terriers each built from a different combination of kits and scratch built components. The wheels sat so low between the

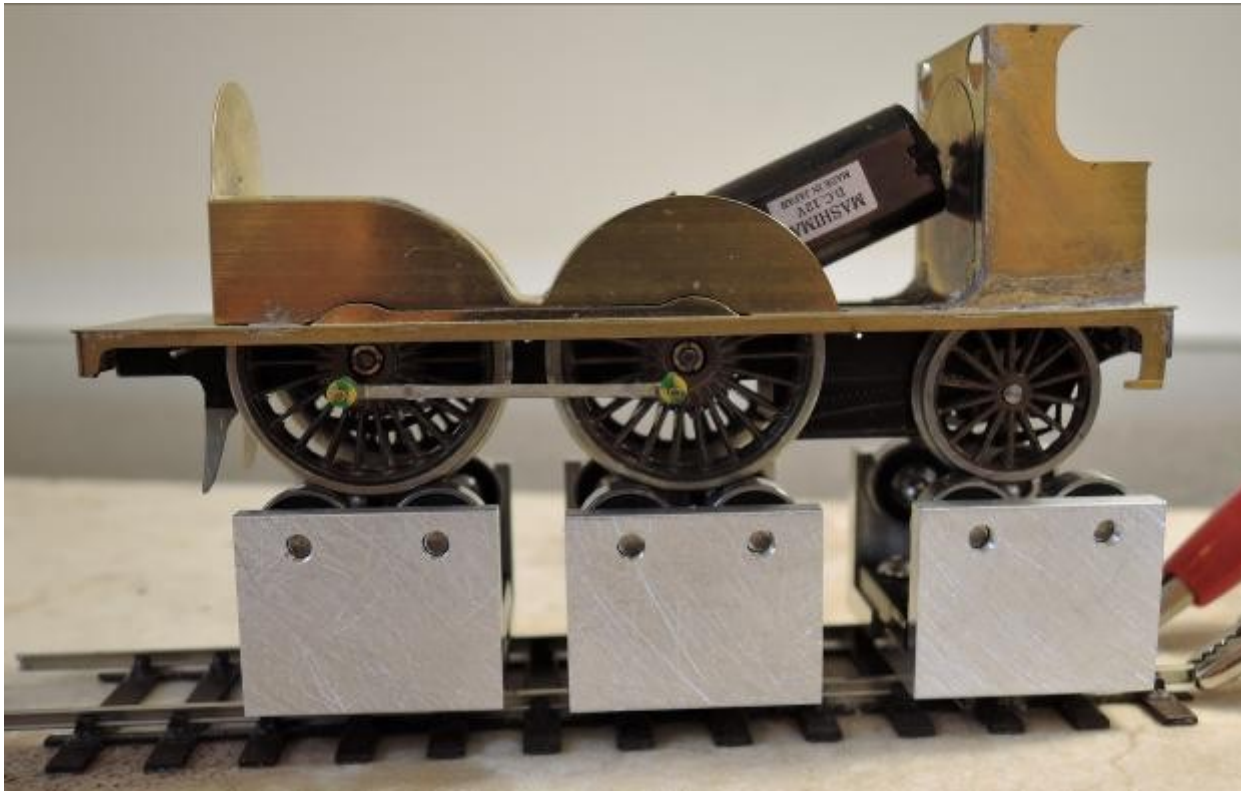

roller bearings that the brake pull rods shorted against them, so a Terrier would have to be fully tested before they were fitted. It was possible crudely to operate a completed model by moving the cradles slightly apart so that the wheels did not drop fully into the gap between the rollers, or by fixing a slip of tape along the lower edge of the offending pull rods. Hardly a satisfactory solution and closer set roller bearings would be needed to use the units for locos with small driving wheels and low set brake parts. However, closer set rollers would not

provide a stable surface for locos with large drivers.

Extra cradles might come in handy for supporting a tender if that is vital to the power supply of a model but all that is really needed is another scrap of track placed on a small raised platform and provided with power.

So was it worth it? I think so, especially as the Hornby product is about £50 and there are others costing a great deal more. The simple design of the Direct Trains product could be emulated in a home-made system, but roller bearing don't come cheap and it might be necessary to go to the trouble of making jigs to ensure precision.

LB&SCR E2 kit

plus some thoughts on 3D printing.

Sparkshot Custom Creations' (SCC)

Having recently introduced a new brand of 4mm, British outline, 3D printed locomotive kits, I was asked to do a short write up of one of them and a bit about 3D printing in general. With an opportunity to share my ideas so early on, I couldn't say no, and I am grateful to the editor for this opportunity.

I have been making models since around the age of 12, and, as an adult, I'm still at it. I have been modelling in 00 for most of the time and in recent years I thought I would have a dab at P4 and join the Scalefour Society: a decision I haven't looked back on and likely never will. I have been fiddling about in 0 but my main focus is P4 and 00. For a number of years the idea of making locomotive kits and accessories through the medium of resin casting has been buzzing around. I still have thoughts about it but after being continually pestered by a good friend, I was finally persuaded to have a bash at 3D printing. So after a bit of tutoring at the basics of 3D modelling, I picked up the programs quickly and from there it's just a matter of practice and experience.

The main direction for the range is pre-grouping, as it is an era that interests me the most. It is



also in many ways the least catered for; the majority of modellers seem to prefer BR, possibly because it is the steam era that so many can remember as a child.

With the LB&SCR E2, my main aim was to improve on the Ready to Run (RTR) product, that has been available for many years, by avoiding the compromises. It looks nice at a glance but is not particularly accurate. As I understand it, the

manufacturer seems to have reduced the overall length by shortening the smoke-box, boiler and bunker and raising the running plate at its highest level in an attempt to fit an older chassis with much bigger wheels. As a result the running plate curves look exaggerated and the whole thing overall is too short.

The other E2 available is a kit that, although is generally a better profile, is not the easiest to put together, in my opinion, and lacks certain details of the RTR version. The same company makes a nice etched chassis for the E2 but, as it is designed to fit several prototypes, is also compromised

around the wheelbase by shifting the centre driver out of alignment. The E2's should have a wheelbase of 16 feet, equally divided. Part of the SCC motivation for the new E2 model was to avoid these compromises, so I took it upon myself to do something about it. The model railway world needs a new E2 and my sincere hope is that people will find the new offerings pleasing – as with the other locos in my range.

I produce the original E2, the extended tank version and a couple of freelance conceptual designs to suit my own purposes and anyone who may want them - all available in different materials. One is known as White Strong Flexible (WSF) nylon, which is very good if you drop it on a hard



kitchen floor! It just bounces and usually nothing breaks off. The disadvantage is you have to put more effort in smoothing it down with abrasive papers and filler primer before painting and it is not quite as fine.

Another option is Frosted Ultra Detail

(FUD) resin, which might have more of a challenge surviving a drop on the kitchen floor but is much smoother, with finer crisper details. This requires less surface preparation and will give the best finish once complete. It's a case of weighing up the perceived advantages and disadvantages and making your choice. For example the tank rivets don't always turn out perfectly in the WSF but these are easily replaced with transfer rivet decals, such as those made by Archer. DCC Supplies is a UK outlet that sells them.

In addition to the E2, there are several different locomotive kits, currently all pre-grouping, now available from SCC through Shapeways.com. Several variants are available, both real and freelance for your own purposes.

When designing a product in 3D, you need to take account of a number of considerations. Firstly, you can't just make a simple 3D mesh drawing, such as those on a computer game, where only the outside visible shell needs to be constructed.

The structure instead needs to be "solid", meaning the inside and the outside perimeters of the model need to be clearly defined with no gaps, otherwise the 3D printer may make a mistake. Many programs offer a solid checking tool and they can be downloaded. Printing tolerances also need to be taken into account in the design stage as these are a function of the printing materials themselves; for example, having walls too thin in a certain material will probably fail in printing.

Other considerations are the same as for etching; what to make, how viable is the design, is there a market? Is it an example that would fill a niche, or too obscure a niche? Then of course there is the issue of drawings. With enough research, you can often eventually acquire drawings – which

may then turn out to be different from each other and differ again from the photographic evidence! Once you have a 3D model completed digitally and scaled, the next stage is to print it out. Several 3D printers are available for home use, often as kits, but these are not cheap – especially ones with good resolution. The current preference is therefore to use companies such as Shapeways, iMaterialise and similar.

With Shapeways, you upload your design and the computer system automatically tells you how



much it will cost in several different materials. It also alerts you to possible printing problems, such as issues around tolerances and thickness.

The current range includes loco bodies, chassis, brass coupling rods and accessories. As with any kit, it is best to complete a test build to trial the design before it reaches paying customers. In this case, it involves purchasing your own design from the printer as a prototype. The next stage is pretty much the same as any other kit; add your preferred running gear - wheels, motor, gearbox and so on that turn it into a working model. It is at this stage you will be able accurately to assess any remedial work needed on the 3D meshes, before you are sure it is safe and at a good quality for sale. Chassis fitting and clearances for wheels are the main things to look out for, although good design digitally will usually enable you to do this in one hit.

Unlike RTR locos that are complete and ready to run, traditional kits require the builder to do a lot of work before the model is complete. SCC loco kits are a sort of halfway house between the two extremes, requiring less effort to complete and therefore making a great introductory route to loco kit building. The chassis is printed square, with the main block complete, removing a lot of the bother of joining the two sides accurately. For experienced builders this is fine, but for many newcomers the prospect of accurately soldering up a kit can be horrifying and this is what puts many off making the first step.

Brake blocks are already in position and the brake rodding is sprued as one piece, designed to be removable. The bodies just require hand rails and couplings etc to complete but, as with all kits, if you want to tweak things or replace buffer heads and such like, the option is there. I am always pleased to see the finished results if you are willing to share them.

For more information, each product has its instructions in the description and for a video of some initial prototypes running in 00, please see the following clip

<https://www.youtube.com/watch?v=GueZnmgf410>

For the [website](#) and complete list of products please go to

<http://www.shapeways...tomcreationscc>

All the printing, packaging, posting and customer service is done by Shapeways but all the designing and creating is currently done by me. Please feel free to send an email to sparkshot082@gmail.com for any questions or possible customs jobs that may be considered. Also please note, the photographs in this article are all builds in the cheaper WSF material, the finer FUD is also available as described above

Photographs copyright Sparkshot Custom Creations

[Index](#)

3D printing – a first attempt.

by Ian MacCormac

I was given the use of a fairly basic 3D printer the other day just as I was starting to build a 7mm Albion Models D tank. I have built some 4mm ones in the past and they are nice kits but I do not like the way the roof comes out. I cannot get an accurate representation of Stroudley's pressed steel, anti-drum shape.

This illustrates my attempt, using the etches from the kit.



The drawings show a very different shape: The front and side views from various GA's.

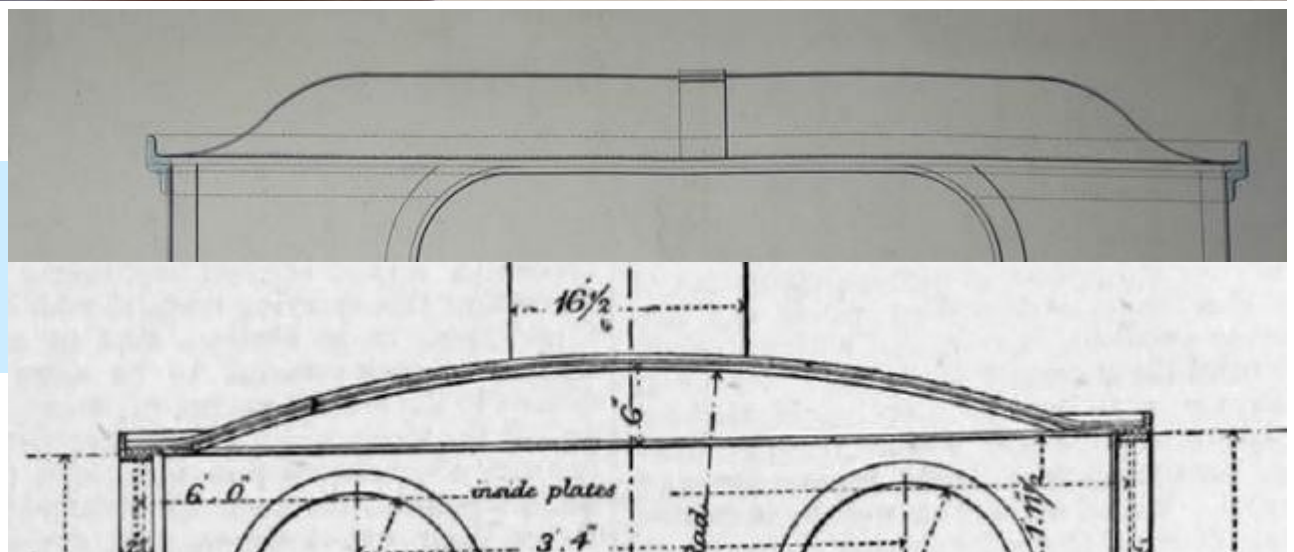



These photographs show what I am trying to achieve:

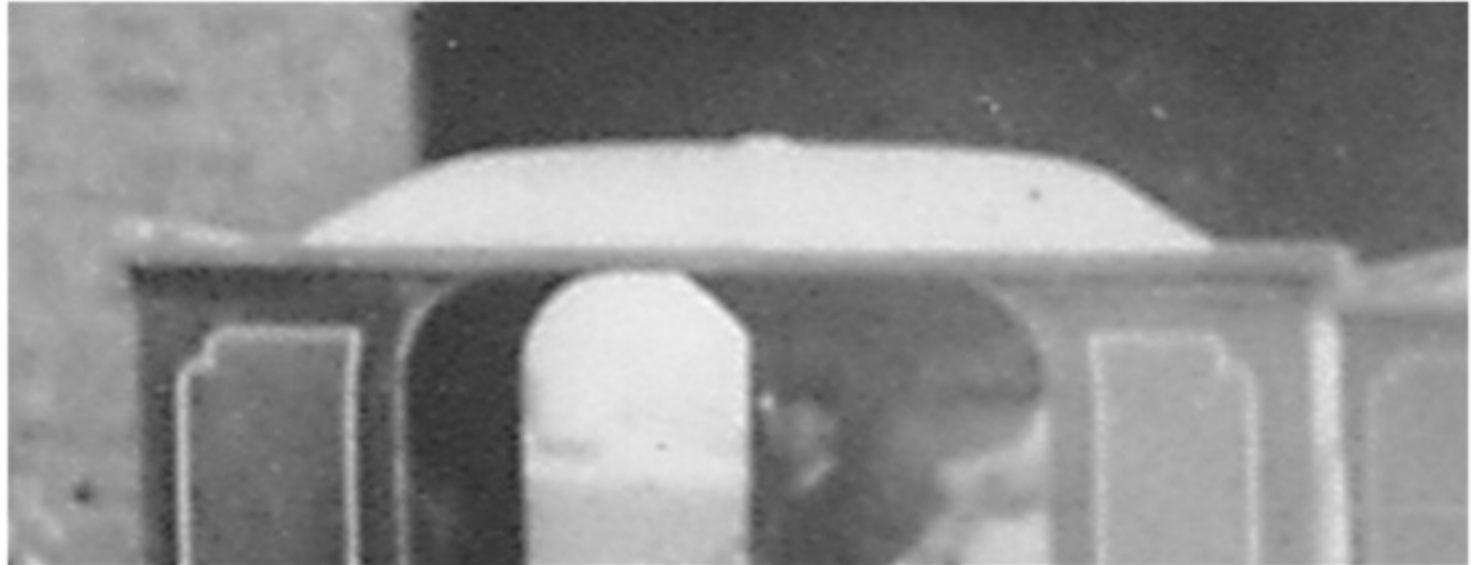
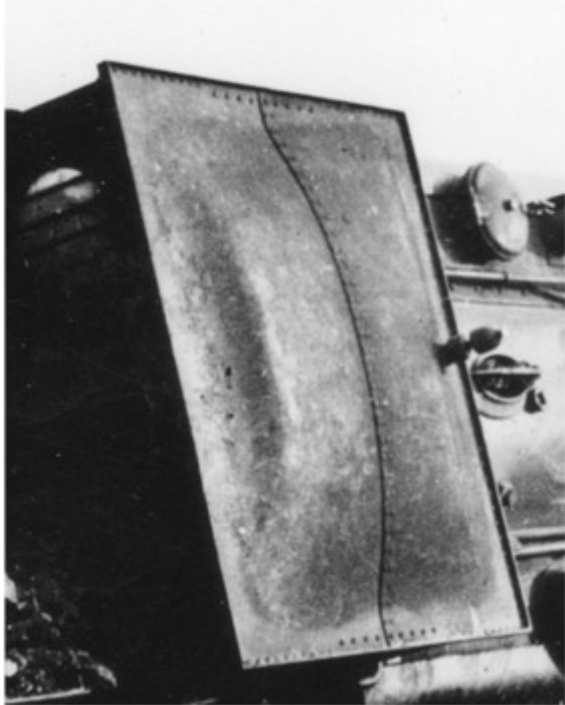

I then tried to find a free 3D design piece of software. I came across DesignSparkMechanical which is something to do with RadioSpares (RS Components) and although free, seems to be able to do most of what I needed for this first go at 3D drawing. I started to draw the roof and found it easier to draw only half of it.



These drawings show this and I was able to draw it full size for 7mm scale quite easily.

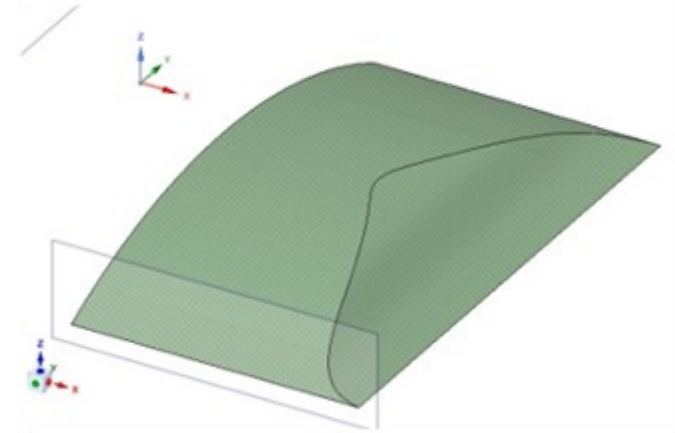

The software generated an .stl file (stereolithography) which is then opened in the programme that controls the 3D printer. This is called ReplicatorG and to the right is a screen shot from that:

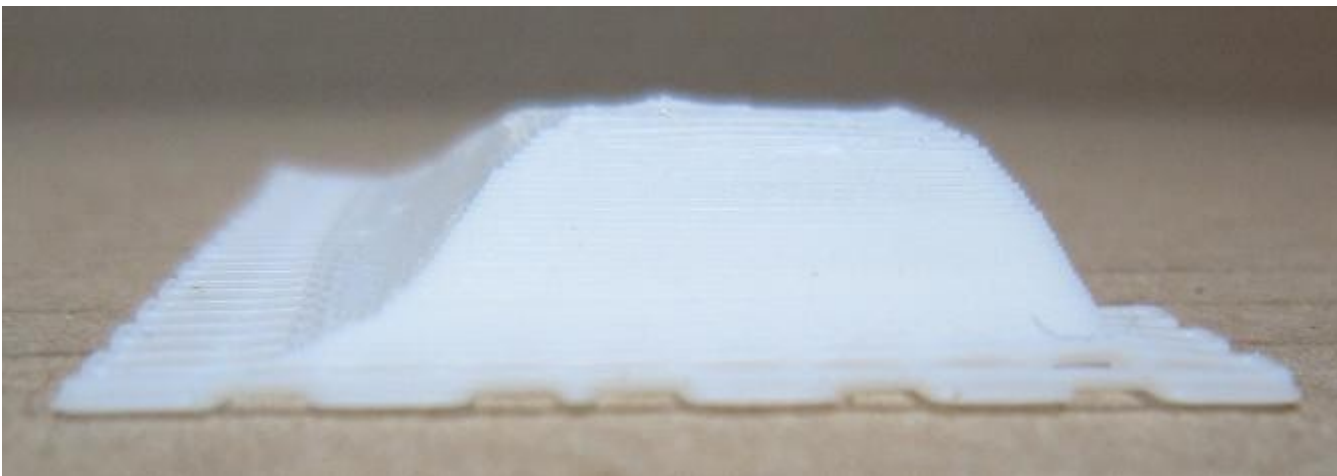
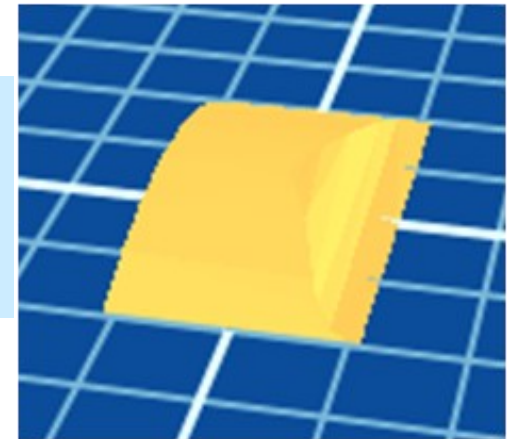

I then got this to work and 9 minutes later had half a 7mm scale Stroudley cab roof, at a resolution of 0.15mm which means there are little steps showing on the curved parts.

It is made from ABS and is sitting on a mesh of this that is the first thing printed. It sticks to the bed of the machine and then this lowers in 0.15mm increments as each layer of the ABS is printed. After cutting away the mesh we get this:

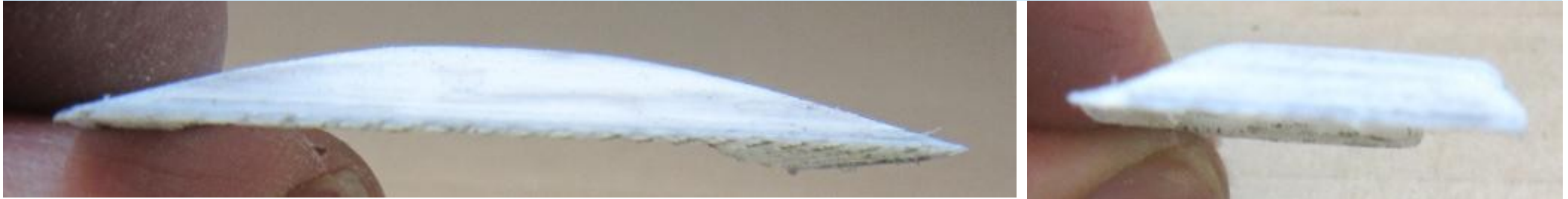

This can then be sanded smooth and have 'Plasticweld' painted on it to help smooth it further. I am quite pleased with the final result and have printed some others to complete the roof. I will then cut the middle out of the brass of the Albion Models kit and glue in this replacement.



Hopefully, I will have completed this and will be able to report further in the next edition.

Photographs copyright Ian McCormac

[Index](#)

The Silhouette Cameo Plotter Cutter – Update

by Ian White

In Issue 2 I described the use of the Cameo plotter cutter at some length. Two points need revising. Firstly, the blade depth settings stated were for one particular blade and proved too deep for the next blade I used, which required settings of only 1 for engraving, or 5 to cut through 10 thou sheet. Some blades when retracted have settings starting below the zero position, which suggests that it is the number of clicks from start that matters, not the number on the scale. Given that cutting deeper than needed results in the wrecking of an area of cutting mat it is advisable to test a new blade carefully!

The other problem I encountered was with file transfer. Other model makers have recommended the use of a free drawing and design package called *Inkscape* either to develop designs or as an intermediary between CAD software such as *TurboCAD* and the plotter's own software. I suggested that it was possible to go direct from *TurboCAD* by exporting an SVG file, which could then be loaded into the *Designer* edition of the plotter's software. That can work but I discovered a compatibility problem in which sections of ellipse or other curves of uneven radius are replaced by a series of long straight lines. The solution is to save a DXF file from *TurboCAD* (delete any hidden layers first); import the DXF file into *Inkscape* and then save as an SVG file; import that SVG file into the plotter software and curves will be curved! Luckily there is no need to learn to use *Inkscape* merely to load a file and then immediately export it again.

Photo 1 right – This partly constructed overshoot water wheel is an example of the type of complex structure that can be built from layers of 10 thou plasticard.

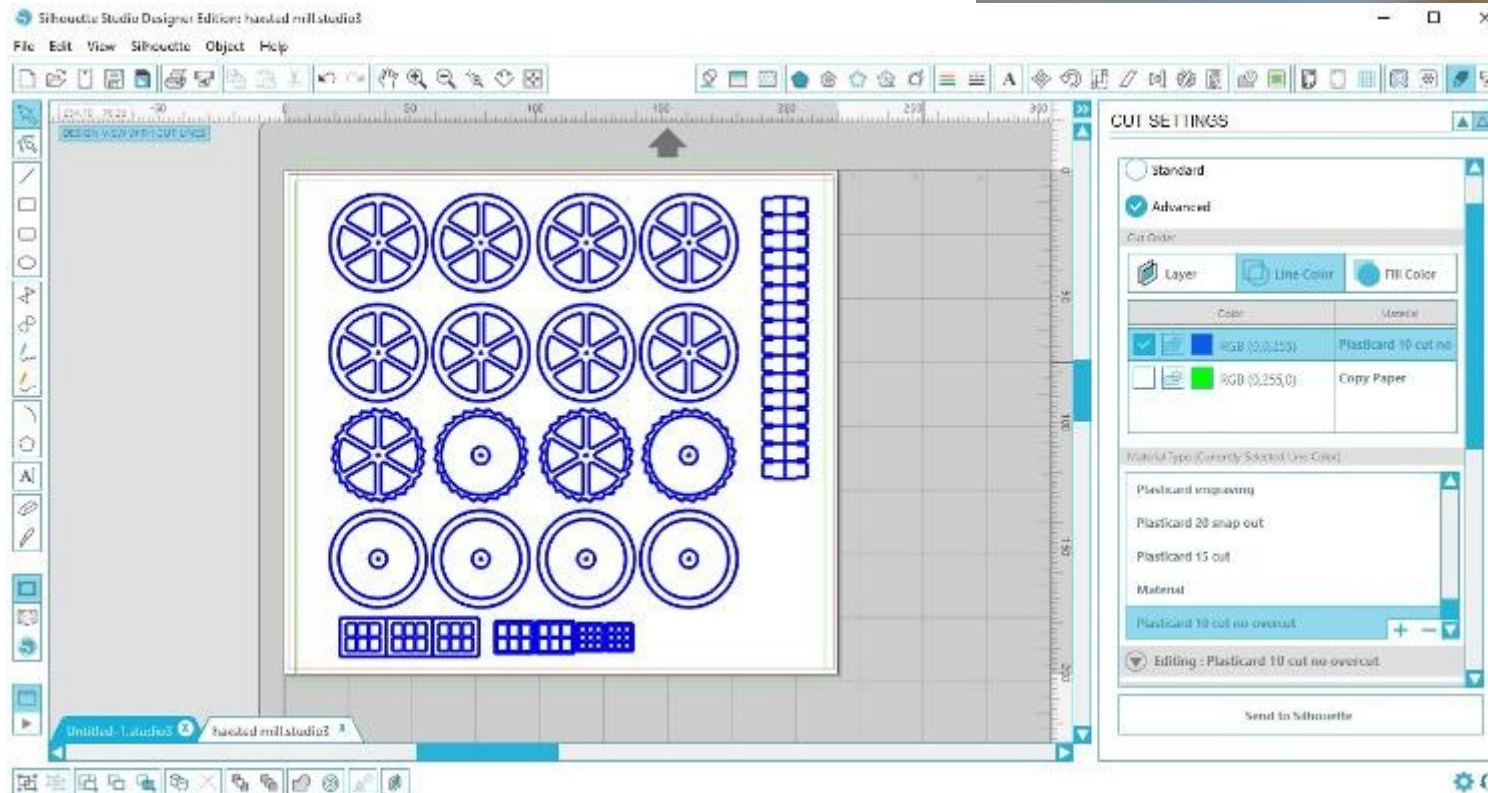
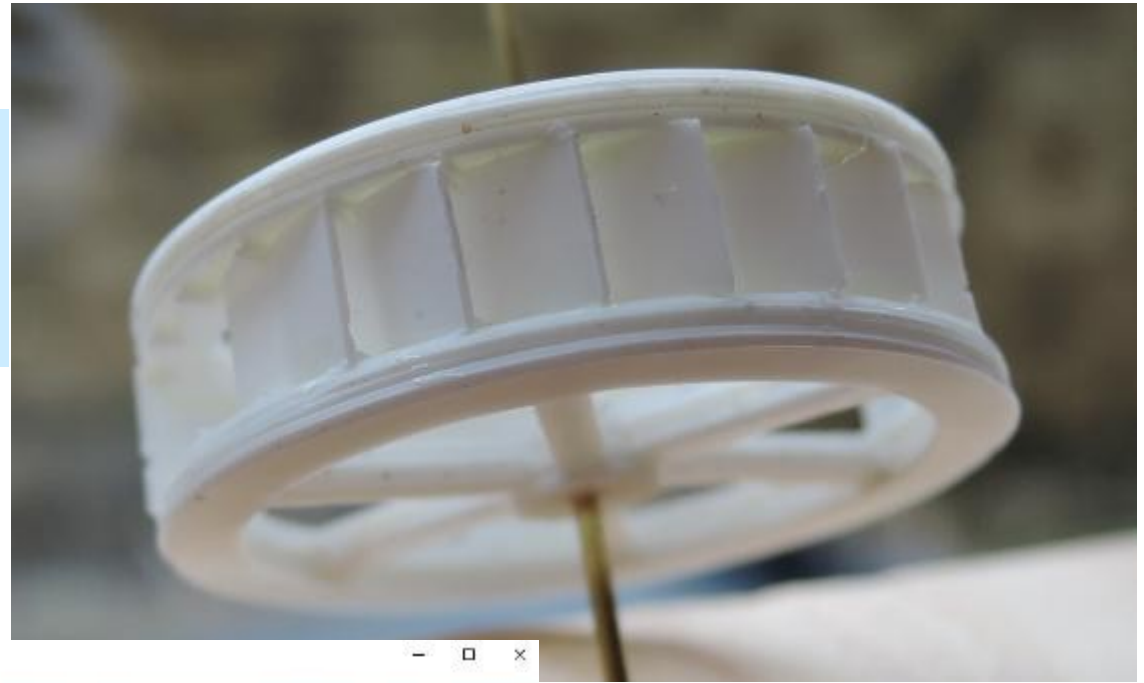

Photo 2 below – A screen shot showing the cutting plan for the mill wheel (and mill windows).

Photographs copyright
Ian White

[Index](#)

Creating and Casting White Metal kits.

By Chris Cox – 5&9Models

Many of us have tackled a white metal kit in our quest to create something ‘a bit different’ from the ready-to-run stock available from the larger model manufacturers. Modelling the LB&SCR requires a good deal of kit making and scratch building, sometimes with some success and sometimes not, depending on a mixture of the kit quality and our own ability or available time.

I have been designing and casting white metal kits for 15 years; some of them have been successful and others, I freely admit, have been absolutely hideous. Hopefully this article will provide an insight into what goes into a kit before it becomes available to the intrepid modeller.

Before any actual model making can begin, a certain amount of research must be carried out on the chosen prototype. I have often left this up to others, to whom I am eternally grateful; I won't list the names here but I'm sure those involved will recognise their extensive input! A drawing is of course a good start, however this is sometimes no evidence that the vehicle in question ever made it out of the drawing office. Some drawings have been extrapolated from grainy photographs, a skill which I certainly don't possess, but I am sure would make an excellent article in its own right.

Once the “evidence” has been gathered, I can make a start on the master, usually using styrene sheet in a variety of thicknesses as required. Buffers and oil lamp pots are lathe-turned from

brass rod. A simple wagon would demand one side and one end, one solebar, two springs, two axle-boxes, two buffers and brake detail, all to be eventually cast twice to create one wagon's worth of castings. A more complicated wagon, such as an end-door, would require both sides, both ends and the full quota of all the other parts before a mould could be made. The same applies to coaches, an asymmetrical vehicle requires twice the amount of work; brake vans are a



good example of this. Certain details such as springs, axle-boxes and buffers can be used across a number of kits, as these were often relatively standard, although the assortment of variants is sometimes surprising. In this case, the masters were produced by Ian White, using the Cameo cutter, which is described in detail in Issue 2 of the Digest.

The casting mould itself is made from cold-cure rubber in two discs: a top and a bottom. These are clamped together between two aluminium plates before being placed in the centrifuge for casting. To make part one of the mould, modelling clay or 'Chavant' is warmed up and pressed onto the base plate inside a nylon ring. The ring determines the dimensions and provides a consistent edge to level the clay to. A nylon plug is placed in the centre, which will form the depression in the base of the finished mould to aid the flow



of hot metal. I then scribe a groove all the way around between the clay and the ring with the occasional random hump. This ensures that the two halves of the mould mate together, perfectly aligned, otherwise offset castings would result, which is particularly irritating with items like buffers. The masters are then positioned equally around the clay, with the larger pieces, such as wagon or coach sides and ends, opposite each other to balance the casting. Smaller parts can be squeezed in and on every mould there is often something to be cast which has nothing to do with the main subject. There

is always an opportunity to make use of a bit of spare space with a figure, window frame or canopy pillar. After all the parts are satisfactorily positioned, and any flat components are pinned down in case they work loose during the next phase, the second ring is placed on. The rubber can now be mixed; 330g of shore 60 rubber, to 10g catalyst, stirred well and placed in a vacuum chamber to 'de-gas'. This takes about 5 minutes during which the rubber boils up, collapses and simmers until all the air is removed. Then it is poured steadily over the centre plug and allowed to drift out over the masters and clay to the outer ring. Once all the rubber is in, the second alloy plate is clamped down on top, the mould is given a gentle spin to work the rubber out to the edges, and any excess air is driven to the centre hole. A final plug is pushed into the centre hole



and it is all left to cure, which takes approximately 5 hours.

The fully cured mould is then opened up and the modelling clay peeled away to leave the masters stuck to the first half of the rubber mould. There is usually a small amount of cleaning up to do where the rubber has flowed over parts of the master where it shouldn't be. After this, the second half of the mould can be cast, repeating the process for the first, although a liberal coating of release wax must be sprayed over the first half mould to prevent

the second half sticking fast. As soon as the second half mould is cured, the two halves are prized apart, the masters taken out, and sprues cut into the rubber to enable the hot metal to flow to each component void.

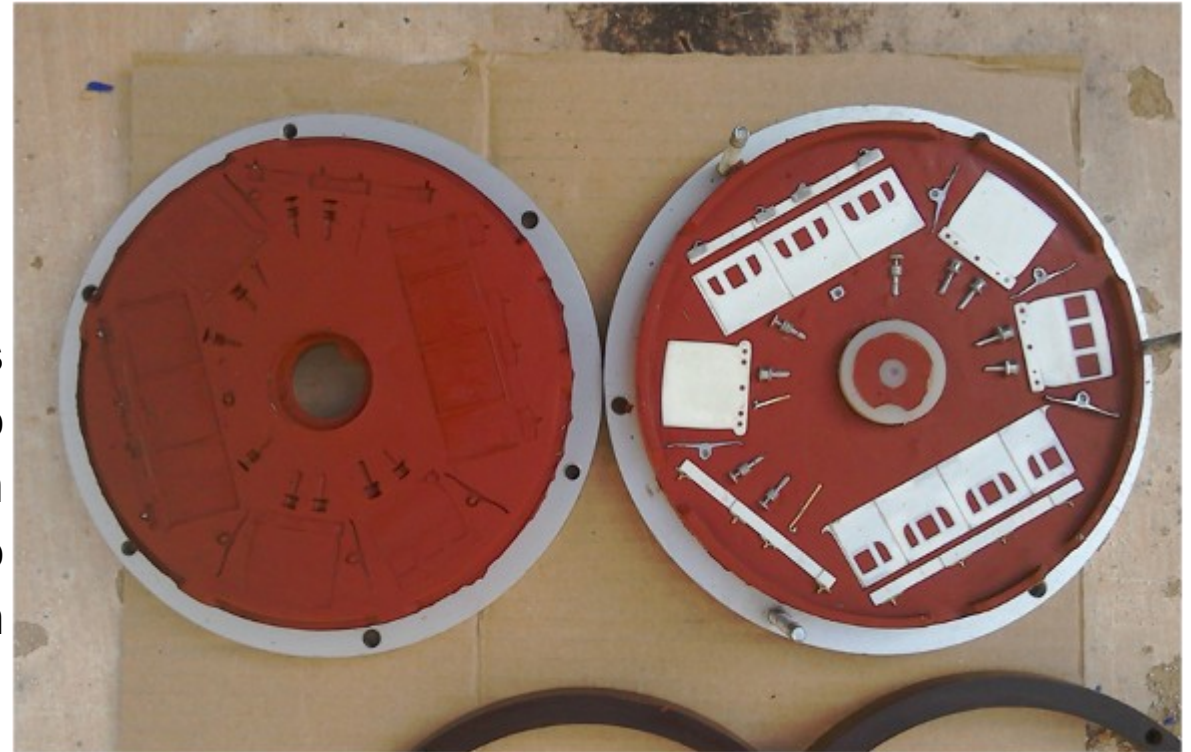

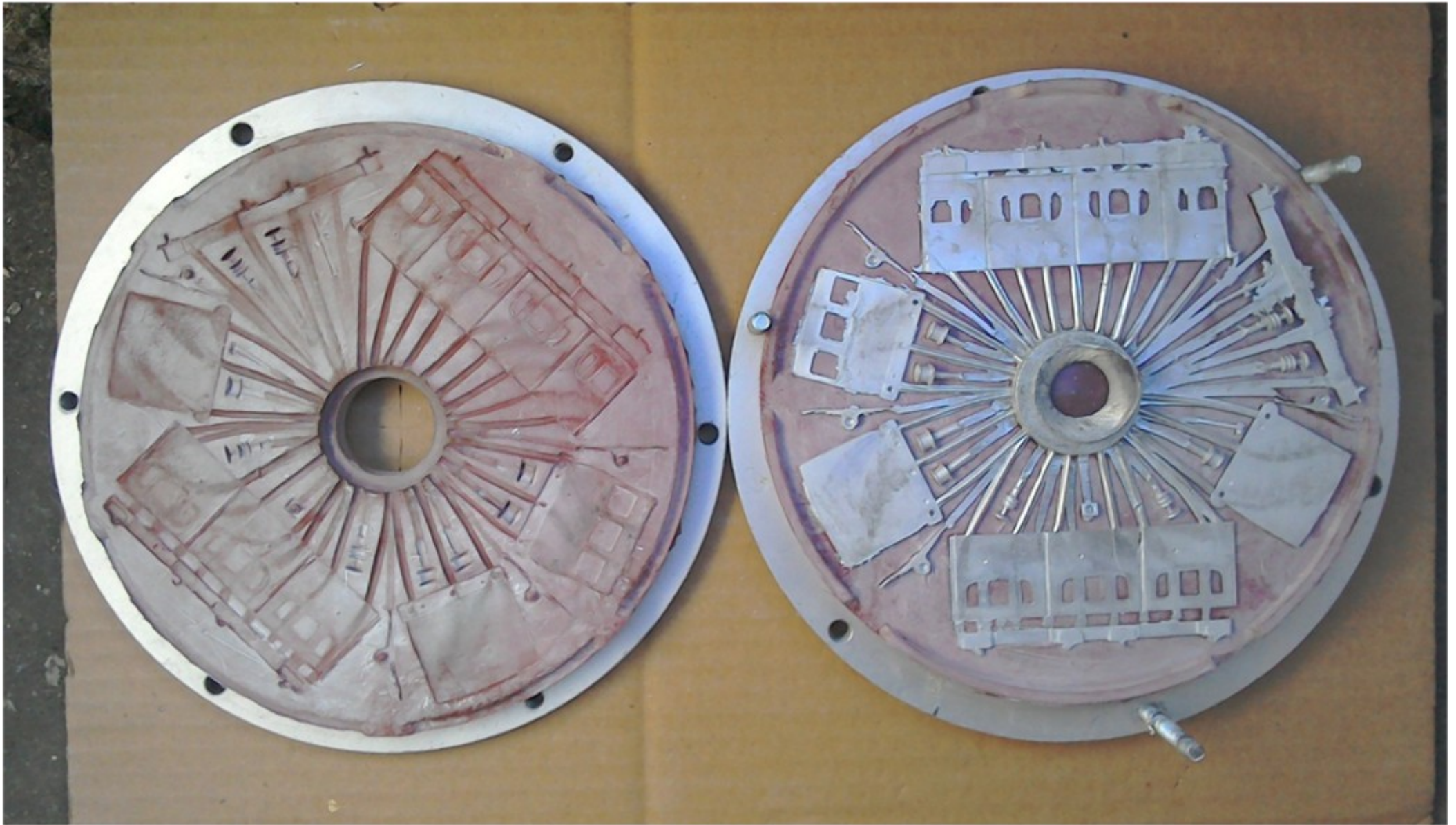

After a dusting of talc to assist with the flow of molten metal, the mould is now ready for casting. The white metal is heated to melting point in a crucible over a gas burner, the mould is set into the centrifuge, spun up and the hot metal poured into the centre hole. When the mould is full, the

centrifuge is turned off and by the time it stops, the metal has solidified and the mould can be opened up to reveal the casting. The general rule is that small chunky parts cast easily and the larger flat areas, vehicle sides and ends require two or three casts to heat the mould up, enabling it to 'settle down'. Very fine parts can be problematic in terms of getting the metal to flow into the fine detail, and there is always one part which steadfastly refuses to cast at all! At this point the sprue and parts are lifted out and the mould made ready for the next casting. Once I have cast enough for a few kits, the crucible and centrifuge are turned off, and the components trimmed from the sprue. The sorting and packing of each kit takes longer than the casting process itself. If it is a new kit, then I prefer to build a sample to completion before advertising its availability. Occasionally an error will creep in which only becomes apparent when building the sample. If serious, then a replacement part will have to be made and put into the next mould. In this way, some kits take a very long time to develop, as I may not have another mould in the pipeline. Upon completion of the sample, I then photograph it, write the instructions, and order any supplementary parts, such as etched w irons and pin-point bearings, before packing up the kits. It is a long winded process and the cost of mould rubber and white metal can be expensive. However, the journey is an interesting and enjoyable one, and the ability to cast duplicates whenever required is, in theory, very useful. However even after 15 years I have yet to build two of anything!

Photographs copyright Chris Cox

[Index](#)

LB&SCR CARRIAGES Vol 2

By Ian White, Simon Turner and Sheina Foulkes

It is now almost forty years since the publication of *Carriage Stock of the LB&SCR* by PJ Newbury, and twenty since David Gould produced *Bogie Carriages of the London, Brighton & South Coast Railway*. This new book is the second of two volumes intended to complete the coverage of LB&SCR carriages and passenger-rated vans. It describes the four and six-wheeled saloon and passenger-rated vans, and also gives an account of the restoration of LB&SCR carriages at the Bluebell Railway.

The aim is to provide a “design history” based on contemporary historical documents supplemented by practical knowledge gained through the study and restoration of surviving carriage bodies. The two volumes describe how carriage design developed, and how it followed new developments in train lighting, braking, communication and the social distinctions of the time.



Both volumes are profusely illustrated with photographs and scale drawings, and are produced to the same high standard as this publisher's *LSWR Carriages* by Gordon Weddell.

All royalties from the sale of these volumes are being donated to the Bluebell Stroudley Coach Fund.

Kestrel Railway Books, PO Box 269, SOUTHAMPTON SO30 4XR

Tel: 01489 798141

info@kestrelrailwaybooks.co.uk

www.kestrelrailwaybooks.co.uk

Available: 29th April 2016

Price: £29.95

ISBN: 978-1-905505-36-4

Hardback, 305mm x 217mm

Over 200 pages with approximately 200 photographs and scale drawings, some in colour

Available from your usual source, or direct from the publisher

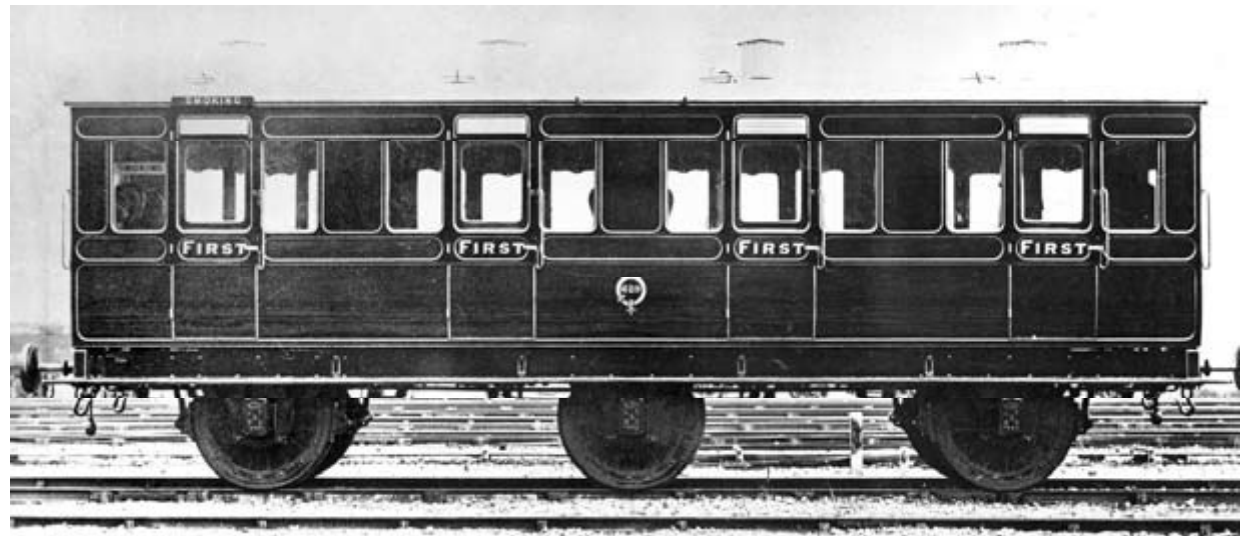

Southern Style Part 2

The London, Brighton & South Coast Railway

Compiled for the HMRS by Peter Wisdom of the Brighton Circle
120pp, A4, softback, illustrated with 170 plates and 100 drawings, comes complete with painted colour samples for 15 of the most important colours used by the company.



Covers: Locomotives; Carriages and NPC's stock; Goods stock; Armorial devices; Carriage interiors; Carriage roofs; Departmental stock; Headcode boards and Regalia; Locomotive shed codes;



Locomotive lamps; Last Vehicle boards; Locomotive painting specifications; Motor train connections; Named locomotives in umber livery; Works Grey and Khaki liveries; Pullman liveries; Road vehicles; Shipping; Signalling; Signage, Running in boards and Signal box nameplates; Structures; Wagon sheets.

£28 to the public.

£18.75 to HMRS and Brighton Circle members.

Plus £3 post & packing



1 2 3 4 5
6 7 8 9 0

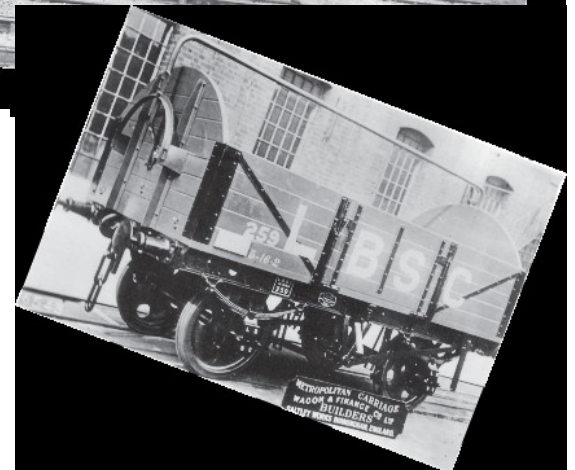

Brighton Layouts that you may see at Exhibitions

[Ferring](#)

[East Grinstead](#) see linked website

[Plumpton Green](#) see linked website

[Hailsham](#) see linked website

[Saltdean](#) see linked website

[Index](#)

The Brighton Circle

The Brighton Circle is the Historical Society of the London, Brighton and South Coast Railway (L.B& S.C.R.). It is dedicated to the research and publication of information about the company and it produces a quarterly journal entitled the Brighton Circular.

While the Circle is primarily focussed on railway historical research, there has been an important interaction with preservationists, particularly on the Bluebell Line, and with railway modellers. The Bluebell line provides an important source of original artefacts, which contribute valuable information about the company's practice. Modellers have benefitted by access to data about the physical appearance of the company and its operations and, as a result, members of the Circle have been able to produce scratch builder aids, paint and lettering on a limited run basis, which are made available among other members.

Membership of the Brighton Circle for 2015 is
£18.00 for full membership

Applications should be sent to

[The Membership Secretary, Peter Wisdom](#)

peter.wisdom.wisdom@btinternet.com

The Circle is also in contact with local historians, industrial archaeologists, family historians and other groups whose interests intersect with those of the Circle.

THE BRIGHTON CIRCLE

An historical society dedicated to the furtherance and publication of original research into the history of the
London, Brighton and South Coast Railway

MEMBERSHIP APPLICATION FORM

To the Hon. Secretary, Peter Wisdom, 76 Woodbourne Avenue, Brighton BN1 8EJ

I hereby apply for membership of the Brighton Circle.

SIGNED..... **DATE**.....

NAME.....

ADDRESS.....

.....

.....**POSTCODE**..... **(BLOCK CAPITALS PLEASE)**

It would be helpful if you could give some idea of your main interests in the history of the LB&SCR and any special interests. Please indicate if you are a modeller and give any details.

I enclose a cheque/postal order for £19.00/£10.00 to cover the joining fee of £1.00 plus twelve/six months membership of the Brighton Circle for the calendar year 2015 (please delete as necessary).

Cheques should be made payable to **The Brighton Circle**.

L

V